

# PALINDROMIC POLYNOMIAL EIGENVALUE PROBLEMS: GOOD VIBRATIONS FROM GOOD LINEARIZATIONS\*

D. STEVEN MACKEY<sup>†</sup>, NILOUFER MACKEY<sup>‡</sup>, CHRISTIAN MEHL<sup>§</sup>, AND VOLKER MEHRMANN<sup>§</sup>

**Abstract.** Palindromic polynomial eigenvalue problems and related classes of structured eigenvalue problems are considered. These structures generalize the concepts of symplectic and Hamiltonian matrices to matrix polynomials. We discuss several applications where these matrix polynomials arise, and show how linearizations can be derived that reflect the structure of all these structured matrix polynomials and therefore preserve symmetries in the spectrum.

**Key words.** nonlinear eigenvalue problem, palindromic matrix polynomial, even matrix polynomial, odd matrix polynomial, Cayley transformation, linearization, Hamiltonian matrix, symplectic matrix

**AMS subject classification.** 65F15, 15A18, 15A57, 93B60

**1. Introduction.** We consider  $n \times n$  matrix polynomials of the form

$$P(\lambda) = \sum_{i=0}^k \lambda^i A_i, \quad A_1, \dots, A_k \in \mathbb{F}^{n \times n}, \quad A_k \neq 0 \quad (1.1)$$

where  $\mathbb{F}$  denotes the field  $\mathbb{R}$  or  $\mathbb{C}$ . The numerical solution of the associated polynomial eigenvalue problem  $P(\lambda)x = 0$  is one of the most important tasks in the vibration analysis of buildings, machines and vehicles [9], [18], [31], as well as in many other applications.

As illustrated by the examples presented in Section 3, matrix polynomials arising in a variety of applications have extra structure that results in symmetries in the spectrum. Our focus here is on matrix polynomials with the property that reversing the order of the coefficient matrices, followed perhaps by taking their transpose or conjugate transpose, leads back to the original matrix polynomial. By analogy with linguistic palindromes, of which

Sex at noon taxes

is perhaps a less well-known example\*\*, we refer to the polynomials studied in this paper as *palindromic matrix polynomials*.

Palindromic matrix polynomials can be thought of as generalizations of symplectic matrices, because they are strongly related (via the *Cayley transformation*) to *even/odd matrix polynomials*, which represent generalizations of Hamiltonian matrices. Even and odd matrix polynomials, albeit under different nomenclature, have recently received a lot of attention in [2], [4], [28], [29]. Due to their intimate relationship odd/even and palindromic matrix polynomials can be studied in a similar way.

The classical approach to investigate or numerically solve polynomial eigenvalue problems is *linearization*, in which the given polynomial (1.1) is transformed into a  $kn \times kn$  matrix pencil  $L(\lambda) = \lambda X + Y$  that satisfies

$$E(\lambda)L(\lambda)F(\lambda) = \begin{bmatrix} P(\lambda) & 0 \\ 0 & I_{(k-1)n} \end{bmatrix}, \quad (1.2)$$

---

\*Supported by Deutsche Forschungsgemeinschaft through MATHEON, the DFG Research Center *Mathematics for key technologies* in Berlin.

<sup>†</sup>School of Mathematics, The University of Manchester, Sackville Street, Manchester, M60 1QD, UK. This work was supported by Engineering and Physical Sciences Research Council grant GR/S31693.

<sup>‡</sup>Department of Mathematics, Western Michigan University, Kalamazoo, MI 49008, USA. ([nil.mackey@wmich.edu](mailto:nil.mackey@wmich.edu), <http://homepages.wmich.edu/~mackey/>).

<sup>§</sup>Technische Universität Berlin, Institut für Mathematik, Sekretariat MA 4-5, D-10623 Berlin, Germany. ([mehl@math.tu-berlin.de](mailto:mehl@math.tu-berlin.de), [mehrmann@math.tu-berlin.de](mailto:mehrmann@math.tu-berlin.de)).

\*\*Invented by the mathematician Peter Hilton in 1947 for his advisor J.H.C. Whitehead. It is probable, Hilton says, that this palindrome might have been invented before. When Whitehead lamented its brevity, Hilton responded with the palindromic masterpiece “Doc, note, I dissent. A fast never prevents a fatness. I diet on cod.” [15]

where  $E(\lambda)$  and  $F(\lambda)$  are *unimodular matrix polynomials* [9]. (A matrix polynomial is called *unimodular* if it is square and its determinant is a nonzero constant, independent of  $\lambda$ .) Standard methods for linear eigenvalue problems as in [1], [22], [25] can then be applied.

The block-companion forms [9] provide the standard examples of linearizations for a matrix polynomial (1.1). Let  $X_1 = X_2 = \text{diag}(A_k, I_n, \dots, I_n)$ ,

$$Y_1 = \begin{bmatrix} A_{k-1} & A_{k-2} & \cdots & A_0 \\ -I_n & 0 & \cdots & 0 \\ & \ddots & \ddots & \vdots \\ 0 & & -I_n & 0 \end{bmatrix}, \quad \text{and} \quad Y_2 = \begin{bmatrix} A_{k-1} & -I_n & & 0 \\ A_{k-2} & 0 & \ddots & \\ \vdots & \vdots & \ddots & -I_n \\ A_0 & 0 & \cdots & 0 \end{bmatrix}.$$

Then  $C_1(\lambda) = \lambda X_1 + Y_1$  and  $C_2(\lambda) = \lambda X_2 + Y_2$  are the *first and second companion forms* for  $P(\lambda)$ , respectively.

Unfortunately, these block-companion linearizations do not reflect the structure present in palindromic, even, or odd matrix polynomials. The corresponding linearized pencil can usually only be treated with methods for general matrix pencils. But, in a finite precision environment, a numerical method that ignores the structure may produce physically meaningless results [31] and, for instance, lose symmetries in the spectrum. Therefore, it is important to construct linearizations that reflect the structure of the given matrix polynomial, and then develop numerical methods for the corresponding linear eigenvalue problem that properly address these structures as well. The latter topic has been an important area of research in the last decade, see, e.g., [4], [5], [6], [26], [28] and the references therein.

In this paper we investigate structure preserving linearizations using the recently introduced systematic linearization approach of [23]. We construct pencils that have the same structure as the underlying matrix polynomials, and give necessary and sufficient conditions for these pencils to be linearizations, thus correctly representing the information on eigenvalues and eigenvectors of the matrix polynomials.

The subtitle “good vibrations from good linearizations” refers to a palindromic polynomial eigenvalue problem that initiated this research. Outlined in Example 3.1, this problem arises in the vibration analysis of rail tracks excited by high speed trains. In order to compute “good vibrations”, i.e., accurate eigenvalues and eigenvectors, “good linearizations” are necessary, i.e., linearizations of the underlying palindromic matrix polynomial that reflect the palindromic structure [13], [14], [16].

The palindromic and odd/even polynomials that are the focus of this paper are defined in Section 2, where we also establish the spectral symmetries corresponding to each structure. A number of applications that lead to these types of structured polynomial are then described in Section 3. Extending the notion of *Cayley transformation* to matrix polynomials, we show in Section 4 how this transformation connects (anti)-palindromic and odd/even structures. In Section 5 the general linearization approach of [23] is summarized, and then used in the following section to obtain the main results of this paper: the identification of structure preserving linearizations for the various structured matrix polynomials under consideration. A constructive method for generating these structure preserving linearizations is presented in Section 8, along with tables of such linearizations for low degree structured polynomials.

**2. Basic definitions and properties.** In order to concisely define the structures treated in this paper, we will use the symbol  $\star$  as an abbreviation for transpose  $T$  in the real case and either  $T$  or conjugate transpose  $*$  in the complex case.

DEFINITION 2.1. Let  $Q(\lambda) = \sum_{i=0}^k \lambda^i B_i$  be a (possibly rectangular) matrix polynomial, where  $B_1, \dots, B_k \in \mathbb{F}^{m \times n}$ ,  $B_k \neq 0$ . Then we define the adjoint  $Q^\star(\lambda)$  and the reversal  $\text{rev}Q(\lambda)$  of  $Q(\lambda)$ , respectively, by

$$Q^\star(\lambda) := \sum_{i=0}^k \lambda^i B_i^\star \quad \text{and} \quad \text{rev}Q(\lambda) := \lambda^k Q(1/\lambda) = \sum_{i=0}^k \lambda^{k-i} B_i. \quad (2.1)$$

In general,  $\deg(\text{rev}Q(\lambda)) \leq \deg(Q(\lambda))$  and  $\text{rev}(Q_1(\lambda) \cdot Q_2(\lambda)) = \text{rev}Q_1(\lambda) \cdot \text{rev}Q_2(\lambda)$ , whenever the product  $Q_1(\lambda) \cdot Q_2(\lambda)$  is defined.

We say that a matrix polynomial  $P(\lambda)$  is *palindromic* if  $\text{rev}P(\lambda) = P(\lambda)$ , and *anti-palindromic* if  $\text{rev}P(\lambda) = -P(\lambda)$ . Moreover, by analogy with even and odd functions, we say that  $P(\lambda)$  is *even* if  $P(-\lambda) = P(\lambda)$  and *odd* if  $P(-\lambda) = -P(\lambda)$ . We summarize these properties together with their  $\star$ -variants in Table 2.1.

TABLE 2.1  
Basic structures

palindromic	$\text{rev}P(\lambda) = P(\lambda)$	anti-palindromic	$\text{rev}P(\lambda) = -P(\lambda)$
$\star$ -palindromic	$\text{rev}P^\star(\lambda) = P(\lambda)$	$\star$ -anti-palindromic	$\text{rev}P^\star(\lambda) = -P(\lambda)$
even	$P(-\lambda) = P(\lambda)$	odd	$P(-\lambda) = -P(\lambda)$
$\star$ -even	$P^\star(-\lambda) = P(\lambda)$	$\star$ -odd	$P^\star(-\lambda) = -P(\lambda)$

Two matrices that play an important continuing role in our investigation of these structured polynomials are the reverse identity  $R$  in the context of palindromic structures, and the diagonal matrix  $\Sigma$  of alternating signs in the context of even/odd structures:

$$R := R_k := \begin{bmatrix} 0 & & 1 \\ & \ddots & \\ 1 & & 0 \end{bmatrix}_{k \times k}, \quad \text{and} \quad \Sigma := \Sigma_k := \begin{bmatrix} (-1)^{k-1} & & 0 \\ & \ddots & \\ 0 & & (-1)^0 \end{bmatrix}. \quad (2.2)$$

The subscript  $k$  will be dropped whenever it is clear from the context.

A distinguishing feature of the structured matrix polynomials in Table 2.1 is the special symmetry properties of their spectra, described in the following result.

THEOREM 2.2. Let  $P(\lambda)$  be a regular matrix polynomial that has one of the structures listed in Table 2.1. Then the spectrum of  $P(\lambda)$  has the pairing depicted in Table 2.2. Moreover, the algebraic, geometric, and partial multiplicities of the two eigenvalues in each such pair are equal. (Here, we allow  $\lambda = 0$  and interpret  $1/\lambda$  as the eigenvalue  $\infty$ .)

TABLE 2.2  
Spectral symmetries

Structure of $P(\lambda)$	eigenvalue pairing
palindromic, anti-palindromic	$(\lambda, 1/\lambda)$
$T$ -palindromic, $T$ -anti-palindromic	$(\lambda, 1/\lambda)$
$\star$ -palindromic, $\star$ -anti-palindromic	$(\lambda, 1/\bar{\lambda})$
even, odd	$(\lambda, -\lambda)$
$T$ -even, $T$ -odd	$(\lambda, -\lambda)$
$\star$ -even, $\star$ -odd	$(\lambda, -\bar{\lambda})$

*Proof.* We first recall some well-known facts [7], [8], [9] about the companion forms  $C_1(\lambda)$  and  $C_2(\lambda)$  of a regular matrix polynomial  $P(\lambda)$ :

- $P(\lambda)$  and  $C_1(\lambda)$  have the same eigenvalues (including  $\infty$ ) with the same algebraic, geometric, and partial multiplicities.
- $C_1(\lambda)$  and  $C_2(\lambda)$  are always *strictly equivalent*, i.e., there exist nonsingular *constant* matrices  $E$  and  $F$  such that  $C_1(\lambda) = E \cdot C_2(\lambda) \cdot F$ .
- Any pair of strictly equivalent pencils have the same eigenvalues (including  $\infty$ ), with the same algebraic, geometric, and partial multiplicities.

With these facts in hand, we first consider the case when  $P(\lambda)$  is  $\star$ -palindromic or  $\star$ -anti-palindromic, so that  $\text{rev}P^\star(\lambda) = \chi_P P(\lambda)$  for  $\chi_P = \pm 1$ . Our strategy is to show that  $C_1(\lambda)$  is strictly equivalent to  $\text{rev}C_1^\star(\lambda)$ , from which the desired eigenvalue pairing and equality of multiplicities then follows. Using the nonsingular matrix

$$T := \begin{bmatrix} \chi_P I & & & 0 \\ & I & & \\ & & \ddots & \\ 0 & & & I \end{bmatrix} \cdot \begin{bmatrix} I & A_{k-1} & \cdots & A_1 \\ 0 & 0 & & -I \\ \vdots & & \ddots & \\ 0 & -I & & 0 \end{bmatrix},$$

we first show that  $C_1(\lambda)$  is strictly equivalent to  $\text{rev}C_2^\star(\lambda)$ .

$$\begin{aligned} T \cdot C_1(\lambda) \cdot (R_k \otimes I_n) &= T \cdot \left( \lambda \begin{bmatrix} 0 & & A_k \\ & \ddots & I \\ I & & 0 \end{bmatrix} + \begin{bmatrix} A_0 & A_1 & \cdots & A_{k-1} \\ 0 & 0 & & -I \\ \vdots & & \ddots & \\ 0 & -I & & 0 \end{bmatrix} \right) \\ &= \lambda \begin{bmatrix} \chi_P A_1 & \cdots & \chi_P A_{k-1} & \chi_P A_k \\ -I & & 0 & 0 \\ & \ddots & \vdots & \\ 0 & & -I & 0 \end{bmatrix} + \begin{bmatrix} \chi_P A_0 & & & 0 \\ & I & & \\ & & \ddots & \\ 0 & & & I \end{bmatrix} \\ &= \lambda \begin{bmatrix} A_{k-1} & -I & & 0 \\ \vdots & & \ddots & \\ A_1 & 0 & & -I \\ A_0 & 0 & \cdots & 0 \end{bmatrix}^\star + \begin{bmatrix} A_k & & & 0 \\ & I & & \\ & & \ddots & \\ 0 & & & I \end{bmatrix}^\star \\ &= \text{rev}C_2^\star(\lambda). \end{aligned}$$

But  $\text{rev}C_2^\star(\lambda)$  is always strictly equivalent to  $\text{rev}C_1^\star(\lambda)$ , since  $C_1(\lambda)$  and  $C_2(\lambda)$  are. This completes the proof for this case.

For the case of palindromic or anti-palindromic matrix polynomials, i.e., polynomials  $P(\lambda)$  satisfying  $\text{rev}P(\lambda) = \chi_P P(\lambda)$ , an analogous computation shows that

$$T \cdot C_1(\lambda) \cdot (R_k \otimes I_n) = \text{rev}C_1(\lambda),$$

i.e.,  $C_1(\lambda)$  is equivalent to  $\text{rev}C_1(\lambda)$ , which again implies the desired eigenvalue pairing and equality of multiplicities.

Next assume that  $P(\lambda)$  is  $\star$ -even or  $\star$ -odd, so  $P^\star(-\lambda) = \varepsilon_P P(\lambda)$  for  $\varepsilon_P = \pm 1$ . We show that the first companion form  $C_1(\lambda)$  of  $P(\lambda)$  is strictly equivalent to  $C_1^\star(-\lambda)$ , from which the desired pairing of eigenvalues and equality of multiplicities follows. Starting from  $C_1(\lambda)$ , we first see that

$C_1(\lambda)$  is strictly equivalent to  $C_2^*(-\lambda)$ .

$$\begin{aligned}
& \left( \begin{bmatrix} \varepsilon_P & 0 \\ 0 & -\Sigma_{k-1} \end{bmatrix} \otimes I_n \right) \cdot C_1(\lambda) \cdot (\Sigma_k \otimes I_n) \\
&= \lambda \begin{bmatrix} \varepsilon_P (-1)^{k-1} A_k & & 0 \\ & -I & \\ & & \ddots \\ 0 & & & -I \end{bmatrix} + \begin{bmatrix} \varepsilon_P (-1)^{k-1} A_{k-1} & \cdots & \varepsilon_P (-1)^1 A_1 & \varepsilon_P A_0 \\ & -I & & 0 \\ & & \ddots & \vdots \\ 0 & & & -I & 0 \end{bmatrix} \\
&= -\lambda \begin{bmatrix} A_k & & 0 \\ & I & \\ & & \ddots \\ 0 & & & I \end{bmatrix}^* + \begin{bmatrix} A_{k-1} & -I & & 0 \\ \vdots & & \ddots & \\ A_1 & 0 & & -I \\ A_0 & 0 & \cdots & 0 \end{bmatrix}^* = C_2^*(-\lambda).
\end{aligned}$$

The strict equivalence of  $C_2^*(-\lambda)$  and  $C_1^*(-\lambda)$  now follows from that of  $C_2(\lambda)$  and  $C_1(\lambda)$ , and the proof of this case is complete.

For even or odd polynomials  $P(\lambda)$ , that is  $P(-\lambda) = \varepsilon_P P(\lambda)$ , an analogous computation

$$\left( \begin{bmatrix} \varepsilon_P & 0 \\ 0 & -\Sigma_{k-1} \end{bmatrix} \otimes I_n \right) \cdot C_1(\lambda) \cdot (\Sigma_k \otimes I_n) = C_1(-\lambda)$$

shows that  $C_1(\lambda)$  is strictly equivalent to  $C_1(-\lambda)$ , which implies the desired eigenvalue pairing and equality of multiplicities.  $\square$

If the coefficient matrices of  $P$  are real, then the eigenvalues of a  $\star$ -even or  $\star$ -odd matrix polynomial occur in quadruples  $(\lambda, \bar{\lambda}, -\lambda, -\bar{\lambda})$ . This property has sometimes been referred to as ‘‘Hamiltonian spectral symmetry’’, since real Hamiltonian matrices have such a spectral symmetry [26], [29]. However, this is actually a feature common to Lie algebras associated with any real scalar product, and is not confined to Hamiltonian matrices [24]. Similarly, the eigenvalues of real  $\star$ -palindromic and anti- $\star$ -palindromic matrix polynomials occur not just in pairs but in quadruples  $(\lambda, \bar{\lambda}, 1/\lambda, 1/\bar{\lambda})$ , a property sometimes referred to as ‘‘symplectic spectral symmetry’’, since real symplectic matrices exhibit this behavior. But once again, this type of eigenvalue symmetry is an instance of a more general phenomenon associated with matrices in the Lie group of any real scalar product, such as the real pseudo-orthogonal (Lorentz) groups. See [6], [26] for detailed coverage of Hamiltonian and symplectic matrices, and [10], [24] for properties of matrices in the Lie algebra or Lie group of more general scalar products.

REMARK 2.3. Note that in Definition 2.1 we could have defined the adjoint of an  $n \times n$  matrix polynomial with respect to the adjoint of a *general* scalar product, rather than restricting  $\star$  to just transpose or conjugate transpose. For example, with any nonsingular matrix  $M$  we can define a bilinear scalar product  $\langle x, y \rangle := x^T M y$ , and denote the adjoint of a matrix  $A \in \mathbb{F}^{n \times n}$  with respect to this scalar product by  $A^\star = M^{-1} A^T M$ . (Similarly for a sesquilinear scalar product  $\langle x, y \rangle := x^* M y$  and its corresponding adjoint  $A^\star = M^{-1} A^* M$ .) Then for an  $n \times n$  matrix polynomial  $P(\lambda)$  the definition of the corresponding adjoint  $P^\star(\lambda)$  is formally identical to Definition 2.1; the structures in Table 2.1 also make sense as written with  $\star$  denoting the adjoint of a general scalar product. Well-known examples of this are the skew-Hamiltonian/Hamiltonian pencils [28], which are  $\star$ -odd with respect to the symplectic form defined by  $M = J = \begin{bmatrix} 0 & I \\ -I & 0 \end{bmatrix}$ .

However, not much is gained by this apparent extra generality. Suppose the matrix  $M$  defining a bilinear scalar product satisfies  $M^T = \varepsilon M$  for  $\varepsilon = \pm 1$  (or  $M^* = \varepsilon M$  in the sesquilinear case); this includes all the standard examples, which are either symmetric or skew-symmetric bilinear forms or

Hermitian sesquilinear forms. Then

$$\begin{aligned}
 P(\lambda) \text{ is } \star\text{-palindromic} &\Leftrightarrow \text{rev} P^\star(\lambda) = \text{rev}(M^{-1}P^T(\lambda)M) = P(\lambda) \\
 &\Leftrightarrow \text{rev}(MP(\lambda))^T = \text{rev}(P^T(\lambda)M^T) = \varepsilon MP(\lambda) \\
 &\Leftrightarrow MP(\lambda) \text{ is } T\text{-palindromic or } T\text{-anti-palindromic,}
 \end{aligned}$$

depending on the sign of  $\varepsilon$ . A similar argument shows that  $\star$ -evenness or  $\star$ -oddness of  $P(\lambda)$  is equivalent (in the bilinear case) to the  $T$ -evenness or  $T$ -oddness of  $MP(\lambda)$ . Analogous results also hold in the sesquilinear case when  $M^\star = \varepsilon M$ . Thus for any of the standard scalar products with adjoint  $\star$ , the  $\star$ -structures in Table 2.1 can be reduced to either the  $\star = T$  or  $\star = *$  case; in particular this implies that the eigenvalue pairing results of Theorem 2.2 extend to these more general  $\star$ -structures. Note that this reduction shows the skew-Hamiltonian/Hamiltonian pencils mentioned above are equivalent to  $T$ -even or  $*$ -even pencils.

**3. Applications.** Polynomial eigenvalue problems arise in the analysis and numerical solution of higher order systems of ordinary and partial differential equations. In this section we discuss a variety of applications that lead to structured matrix polynomials.

**EXAMPLE 3.1. (Quadratic complex  $T$ -palindromic matrix polynomials)**

A project of the company SFE GmbH in Berlin investigates rail traffic noise caused by high speed trains [13], [14]. The vibration of an infinite rail track is simulated and analyzed to obtain information on the development of noise between wheel and rail. In the model, the rail is assumed to be infinite and is tied to the ground on sleepers, where neighboring sleepers are spaced  $s = 0.6$  m apart (including the width of one of the sleepers). This segment of the infinite track is called a sleeper bay. The part of the rail corresponding to one sleeper bay is then discretized using classical finite element methods for the model of excited vibration (Figure 3.1).

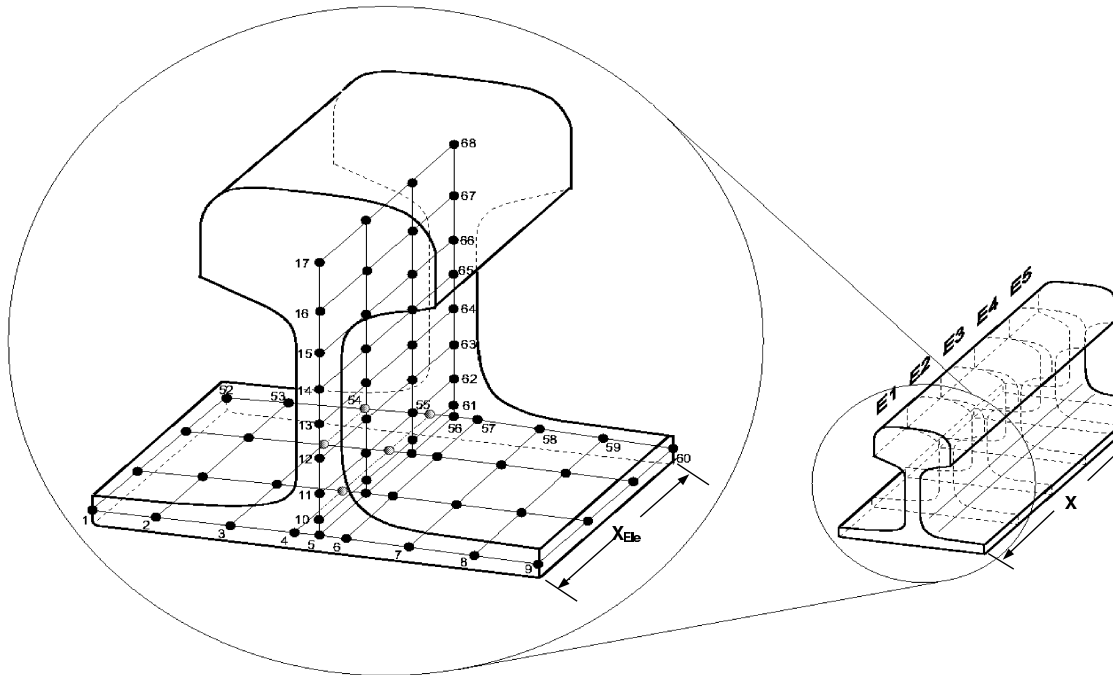

FIG. 3.1. FE discretization of the rail in one sleeper bay.

The discretization leads to an infinite dimensional second order system of the form  $M\ddot{x} + D\dot{x} + Sx = F$ , with infinite block-tridiagonal real symmetric coefficient matrices  $M, D, S$ , where

$$M = \begin{bmatrix} \ddots & \ddots & 0 & \dots & 0 \\ \ddots & M_{j-1,0} & M_{j,1} & 0 & \vdots \\ 0 & M_{j,1}^T & M_{j,0} & M_{j+1,1} & 0 \\ \vdots & \ddots & M_{j+1,1}^T & M_{j+1,0} & \ddots \\ 0 & \dots & 0 & \ddots & \ddots \end{bmatrix}, \quad x = \begin{bmatrix} \vdots \\ x_{j-1} \\ x_j \\ x_{j+1} \\ \vdots \end{bmatrix}, \quad F = \begin{bmatrix} \vdots \\ F_{j-1} \\ F_j \\ F_{j+1} \\ \vdots \end{bmatrix},$$

and where  $D, S$  have the same block structure as  $M$  with blocks  $D_{j,0}, D_{j,1}$  and  $S_{j,0}, S_{j,1}$ , respectively. Here,  $M_{j,0}$  is symmetric positive definite and  $D_{j,0}, S_{j,0}$  are symmetric positive semidefinite for all  $j$ .

There are several ways to approach the solution of the problem, which presents a mixture between a differential equation (time derivatives of  $x$ ) and a difference equation (space differences in  $j$ ).

Since one is interested in studying the behavior of the system under excitation, one makes the ansatz  $F_j = \hat{F}_j e^{i\omega t}$ ,  $x_j = \hat{x}_j e^{i\omega t}$ , where  $\omega$  is the excitation frequency. This leads to a second order difference equation with variable coefficients for the  $\hat{x}_j$  given by

$$A_{j-1,j}^T \hat{x}_{j-1} + A_{jj} \hat{x}_j + A_{j,j+1} \hat{x}_{j+1} = \hat{F}_j,$$

with the coefficient matrices

$$A_{j,j+1} = -\omega^2 M_{j,1} + i\omega D_{j,1} + K_{j,1}, \quad A_{jj} = -\omega^2 M_{j,0} + i\omega D_{j,0} + K_{j,0}.$$

Observing that the system matrices vary periodically due to the identical form of the rail track in each sleeper bay, we may combine the (say  $\ell$ ) parts belonging to the rail in one sleeper bay into one vector

$$y_j = \begin{bmatrix} \hat{x}_j \\ \hat{x}_{j+1} \\ \vdots \\ \hat{x}_{j+\ell} \end{bmatrix},$$

and thus obtain a constant coefficient second order difference equation

$$A_1^T y_{j-1} + A_0 y_j + A_1 y_{j+1} = G_j$$

with coefficient matrices

$$A_0 = \begin{bmatrix} A_{j,j} & A_{j,j+1} & & & 0 \\ A_{j,j+1}^T & A_{j+1,j+1} & \ddots & & \\ & \ddots & \ddots & & \\ 0 & & A_{j+\ell-1,j+\ell}^T & A_{j+\ell,j+\ell} & \end{bmatrix}, \quad A_1 = \begin{bmatrix} 0 & 0 & \dots & 0 \\ \vdots & \ddots & \ddots & \vdots \\ 0 & \dots & 0 & 0 \\ A_{j+\ell,j+\ell+1} & 0 & \dots & 0 \end{bmatrix},$$

that depend on the frequency  $\omega$ . For this system we then make the ansatz  $y_{j+1} = \kappa y_j$ , which leads to the complex eigenvalue problem

$$\frac{1}{\kappa} (A_1^T + \kappa A_0 + \kappa^2 A_1) y = 0.$$

Clearly, the underlying matrix polynomial  $A_1^T + \kappa A_0 + \kappa^2 A_1$  is  $T$ -palindromic, because  $A_0$  is complex symmetric, i.e.,  $A_0 = A_0^T$ . It should be noted that in this application  $A_1$  is highly rank-deficient.

**EXAMPLE 3.2. (Quadratic real and complex  $T$ -palindromic matrix polynomials)**

In [33] the mathematical modelling and numerical simulation of the behavior of periodic surface acoustic wave (SAW) filters is discussed. SAW-filters are piezoelectric devices used in telecommunications, e.g., TV-sets and cell phones, for frequency filtering; other kinds of SAW-devices find application in radar and sensor technology as well as in the field of non-destructive evaluation. In modelling these devices, Floquet-Bloch theory is used in [33] to replace the underlying periodic structure of the problem by a single reference cell together with quasi-periodic boundary conditions. This Bloch-ansatz reduces the problem to calculating the so-called “dispersion diagram”, i.e., the functional relation between the excitation frequency  $\omega$  and the (complex) propagation constant  $\gamma$ . A finite element discretization then leads to a parameter-dependent Galerkin system, which upon further reduction (and invocation of the quasi-periodic boundary conditions) becomes a  $T$ -palindromic quadratic eigenvalue problem

$$(\gamma^2 A + \gamma B + A^T)v = 0, \quad \text{with } B^T = B.$$

Note that  $A$  and  $B$  both depend on the parameter  $\omega$ . If absorbing boundary conditions (necessary for volume wave radiation) are included in the model, then  $A$  and  $B$  are complex, otherwise real.

**EXAMPLE 3.3. (Quadratic \*-palindromic matrix polynomials)**

In [12], bisection and level set methods are presented to compute the Crawford number

$$\gamma(A, B) := \min_{\substack{z \in \mathbb{C}^n \\ \|z\|_2=1}} \sqrt{(z^* A z)^2 + (z^* B z)^2}$$

for two Hermitian matrices  $A, B \in \mathbb{C}^{n \times n}$ . It is shown in [12, Theorem 2.2] that  $\gamma(A, B)$  measures the distance of a Hermitian pair  $(A, B)$  to the nearest non-definite pair in the 2-norm. From [12, formula (2.8)]

$$\gamma(A, B) = \max \left( \max_{0 \leq \theta \leq 2\pi} \lambda_{\min}(A \cos \theta + B \sin \theta), 0 \right),$$

the problem of computing the Crawford number can be reduced to the computation of

$$\max \{ \lambda_{\min}(M(z)) : |z| = 1 \},$$

where  $M(z) = (z^{-1}C + zC^*)/2$  and  $C = A + iB$ . It is easy to check that  $M(z)$  is Hermitian on the unit circle. Since for a given  $\xi \in \mathbb{R}$ , the equivalence

$$\det(M(z) - \xi I) = 0 \iff \det(C - 2\xi z I + z^2 C^*) = 0$$

holds, the authors of [12] discuss the following strategy as a base for a bisection algorithm. Select a value  $\xi \in \mathbb{R}$  and compute the  $2n$  eigenvalues  $z_j$  of the \*-palindromic matrix polynomial  $P(z) = C - 2\xi z I + z^2 C^*$ . For each  $z_j$  on the unit circle compute the smallest eigenvalue  $\lambda_{\min}(M(z_j))$  of  $M(z_j)$ . If  $\lambda_{\min}(M(z_j)) = \xi$  then  $\gamma(A, B) \geq \lambda_{\min}(M(z_j))$ , otherwise we have  $\gamma(A, B) < \lambda_{\min}(M(z_j))$ , and thus,  $\gamma(A, B)$  can be approximated via a bisection method.

**EXAMPLE 3.4. (Quadratic  $T$ -even matrix polynomials)**

The study of corner singularities in anisotropic elastic materials [2], [3], [17], [21], [28], [30] leads to quadratic eigenvalue problems of the form

$$P(\lambda)v = \lambda^2 Mv + \lambda Gv + Kv = 0,$$

with  $M = M^T$ ,  $G = -G^T$ ,  $K = K^T$  in  $\mathbb{R}^{n \times n}$ . The coefficient matrices are large and sparse, having been produced by a finite element discretization. Here,  $M$  is a positive definite mass matrix and  $-K$  is a stiffness matrix. Since the coefficient matrices alternate between real symmetric and skew-symmetric matrices, we see that  $P^T(-\lambda) = P(\lambda)$ , and thus the matrix polynomial is  $T$ -even.

**EXAMPLE 3.5. (Higher degree \*-even matrix polynomials)**

The linear quadratic optimal control problem for higher order systems of ordinary differential equations leads to the two-point boundary value problem for  $2(k-1)$ th order ordinary differential equations of the form

$$\begin{aligned} \sum_{j=1}^{k-1} \begin{bmatrix} (-1)^{j-1} Q_j & M_{2j}^* \\ M_{2j} & 0 \end{bmatrix} \begin{bmatrix} x^{(2j)} \\ \mu^{(2j)} \end{bmatrix} + \\ \sum_{j=1}^{k-1} \begin{bmatrix} 0 & -M_{2j-1}^* \\ M_{2j-1} & 0 \end{bmatrix} \begin{bmatrix} x^{(2j-1)} \\ \mu^{(2j-1)} \end{bmatrix} + \\ \begin{bmatrix} -Q_0 & M_0^* \\ M_0 & -BW^{-1}B^* \end{bmatrix} \begin{bmatrix} x \\ \mu \end{bmatrix} = 0, \end{aligned}$$

where  $W$  and  $Q_j$  are Hermitian for  $j = 1, \dots, k-1$ , see [2], [3], [26], [29]. The substitution  $\begin{bmatrix} x \\ \mu \end{bmatrix} = e^{\lambda t} v$  then yields the eigenvalue problem  $P(\lambda)v = 0$  with the underlying \*-even matrix polynomial of degree  $2(k-1)$  given by

$$\sum_{j=1}^{k-1} \left( \lambda^{2j} \begin{bmatrix} (-1)^{j-1} Q_j & M_{2j}^* \\ M_{2j} & 0 \end{bmatrix} + \lambda^{2j-1} \begin{bmatrix} 0 & -M_{2j-1}^* \\ M_{2j-1} & 0 \end{bmatrix} \right) + \begin{bmatrix} -Q_0 & M_0^* \\ M_0 & -BW^{-1}B^* \end{bmatrix}.$$

**EXAMPLE 3.6. (Higher degree \*-palindromic matrix polynomials)**

Consider the discrete time optimal control problem to minimize

$$\sum_{j=0}^{\infty} \begin{bmatrix} x_j \\ u_j \end{bmatrix}^* \mathcal{Q} \begin{bmatrix} x_j \\ u_j \end{bmatrix}, \quad \mathcal{Q} = \begin{bmatrix} Q & S \\ S^* & R \end{bmatrix} \quad (3.1)$$

subject to the discrete time control

$$\sum_{i=0}^{2\ell} M_i x_{i+\ell} = B u_i,$$

with  $x_0, x_1, \dots, x_{2\ell-1}$  given. Here the coefficients are assumed to satisfy  $Q = Q^* \in \mathbb{F}^{n \times n}$ ,  $M_i \in \mathbb{F}^{n \times n}$  for  $i = 0, \dots, 2\ell$ ,  $S, B \in \mathbb{F}^{n \times m}$ , and  $R = R^* \in \mathbb{F}^{m \times m}$ . (We discuss only the even degree case  $k = 2\ell$ ; the odd degree case is similar but notationally more involved.)

In the classical application from linear quadratic optimal control, the matrix  $\mathcal{Q}$  in (3.1) is symmetric or Hermitian positive semidefinite, with  $R$  being positive definite. In applications from discrete time  $H_\infty$  control, however, both matrices may be indefinite and singular.

The classical way to solve this problem is to turn it into a first order system and to apply the classical techniques for first order systems, see, e.g., [26]. Undoing the transformation to first order leads to a two-point boundary value problem which can be solved via the solution of the polynomial eigenvalue problem for the matrix polynomial

$$\begin{aligned} P_s(\lambda) = \lambda^{2\ell} \begin{bmatrix} 0 & M_0 & 0 \\ M_{2\ell}^* & 0 & 0 \\ 0 & 0 & 0 \end{bmatrix} + \lambda^{2\ell-1} \begin{bmatrix} 0 & M_1 & 0 \\ M_{2\ell-1}^* & Q & 0 \\ 0 & S^* & 0 \end{bmatrix} + \lambda^{2\ell-2} \begin{bmatrix} 0 & M_2 & 0 \\ M_{2\ell-2}^* & 0 & 0 \\ 0 & 0 & 0 \end{bmatrix} \\ + \dots + \lambda^2 \begin{bmatrix} 0 & M_{2\ell-2} & 0 \\ M_2^* & 0 & 0 \\ 0 & 0 & 0 \end{bmatrix} + \lambda \begin{bmatrix} 0 & M_{2\ell-1} & 0 \\ M_1^* & 0 & 0 \\ -B^* & 0 & 0 \end{bmatrix} + \begin{bmatrix} 0 & M_{2\ell} & -B \\ M_0^* & 0 & S \\ 0 & 0 & R \end{bmatrix}. \end{aligned}$$

Then using a non-equivalence transformation, analogous to a technique used in [32], we can transform the matrix polynomial  $P_s(\lambda)$  into a  $*$ -palindromic matrix polynomial of degree  $k = 2\ell$ . Indeed, multiplying  $P_s(\lambda)$  on the left by  $\text{diag}(\lambda^{\ell-1}I_n, I_n, \lambda^\ell I_m)$  and on the right by  $\text{diag}(I_n, \lambda^{1-\ell}I_n, I_m)$  leads to the  $*$ -palindromic matrix polynomial

$$\begin{aligned} P_p(\lambda) = & \lambda^{2\ell} \begin{bmatrix} 0 & M_0 & 0 \\ M_{2\ell}^* & 0 & 0 \\ 0 & S^* & 0 \end{bmatrix} + \lambda^{2\ell-1} \begin{bmatrix} 0 & M_1 & 0 \\ M_{2\ell-1}^* & 0 & 0 \\ 0 & 0 & 0 \end{bmatrix} + \cdots + \lambda^{\ell+2} \begin{bmatrix} 0 & M_{\ell-2} & 0 \\ M_{\ell+2}^* & 0 & 0 \\ 0 & 0 & 0 \end{bmatrix} \\ & + \lambda^{\ell+1} \begin{bmatrix} 0 & M_{\ell-1} & 0 \\ M_{\ell+1}^* & 0 & 0 \\ -B^* & 0 & 0 \end{bmatrix} + \lambda^\ell \begin{bmatrix} 0 & M_\ell & 0 \\ M_\ell^* & Q & 0 \\ 0 & 0 & R \end{bmatrix} + \lambda^{\ell-1} \begin{bmatrix} 0 & M_{\ell+1} & -B \\ M_{\ell-1}^* & 0 & 0 \\ 0 & 0 & 0 \end{bmatrix} \\ & + \lambda^{\ell-2} \begin{bmatrix} 0 & M_{\ell+2} & 0 \\ M_{\ell-2}^* & 0 & 0 \\ 0 & 0 & 0 \end{bmatrix} + \cdots + \lambda \begin{bmatrix} 0 & M_{2\ell-1} & 0 \\ M_1^* & 0 & 0 \\ 0 & 0 & 0 \end{bmatrix} + \begin{bmatrix} 0 & M_{2\ell} & 0 \\ M_0^* & 0 & S \\ 0 & 0 & 0 \end{bmatrix}. \end{aligned}$$

Since  $\det P_p(\lambda) = \lambda^{\ell m} \det P_s(\lambda)$ , it follows that  $P_s(\lambda)$  and  $P_p(\lambda)$  have the same finite eigenvalues (counted with multiplicities) except for  $\ell m$  additional zero eigenvalues of  $P_p(\lambda)$ .

In this section we have presented a wide variety of applications that lead to structured matrix polynomials. In the next section we discuss the relationships between these various types of polynomials.

**4. Cayley transformations of matrix polynomials.** It is well known that the *Cayley transformation* and its generalization to pencils [20], [27] relates Hamiltonian and symplectic matrices and matrix pencils. By extending the classical definition of this transformation to matrix polynomials, we now develop analogous relationships between (anti-)palindromic and odd/even matrix polynomials, and their  $\star$ -variants.

Our choice of definition is motivated by the following observation: the only Möbius transformations of the complex plane that map reciprocal pairs  $(\mu, 1/\mu)$  to plus/minus pairs  $(\lambda, -\lambda)$  are  $\alpha(\frac{\mu-1}{\mu+1})$  and  $\beta(\frac{1+\mu}{1-\mu})$ , where  $\alpha, \beta \in \mathbb{C}$  are nonzero constants. When  $\alpha = \beta = 1$ , these transformations also map conjugate reciprocal pairs  $(\mu, 1/\bar{\mu})$  to conjugate plus/minus pairs  $(\lambda, -\bar{\lambda})$ . Putting this together with Theorem 2.2, we see that the Möbius transformations  $\frac{\mu-1}{\mu+1}, \frac{1+\mu}{1-\mu}$  translate the spectral symmetries of (anti-)palindromic matrix polynomials and their  $\star$ -variants to those of odd/even matrix polynomials and their  $\star$ -variants. Consequently it is reasonable to anticipate that Cayley transformations modelled on these particular Möbius transformations will have an analogous effect on structure at the level of matrix polynomials.

These observations therefore lead us to adopt the following definition as the natural extension, given our context, of the Cayley transformation to matrix polynomials.

**DEFINITION 4.1.** *Let  $P(\lambda)$  be a matrix polynomial of degree  $k$  as in (1.1). Then the Cayley transformation of  $P(\lambda)$  with pole at  $-1$  is the matrix polynomial*

$$\mathcal{C}_{-1}(P)(\mu) := (\mu + 1)^k P\left(\frac{\mu - 1}{\mu + 1}\right), \quad (4.1)$$

*and the Cayley transformation of  $P(\lambda)$  with pole at  $+1$  is the matrix polynomial*

$$\mathcal{C}_{+1}(P)(\mu) := (1 - \mu)^k P\left(\frac{1 + \mu}{1 - \mu}\right). \quad (4.2)$$

The next result shows that when viewed as maps on the space of  $n \times n$  matrix polynomials of degree  $k$ , the Cayley transformations in (4.1) and (4.2) are inverses of each other, except for a scaling factor.

PROPOSITION 4.2. *Let  $Id$  denote the identity map on the space of  $n \times n$  matrix polynomials of degree  $k$ . Then*

$$\mathcal{C}_{+1} \circ \mathcal{C}_{-1} = \mathcal{C}_{-1} \circ \mathcal{C}_{+1} = 2^k \cdot Id.$$

*Proof.* The proof follows from a direct algebraic calculation.  $\square$

The next two lemmas give some straightforward observations that are helpful in relating the structure in a matrix polynomial to that in its Cayley transformations. Recall that  $\star$  denotes either the transpose  $T$  or the conjugate transpose  $*$ .

LEMMA 4.3. *Let  $P$  be a matrix polynomial. Then*

$$(\mathcal{C}_{-1}(P))^\star(\mu) = \mathcal{C}_{-1}(P^\star)(\mu), \quad \text{and} \quad (\mathcal{C}_{+1}(P))^\star(\mu) = \mathcal{C}_{+1}(P^\star)(\mu). \quad (4.3)$$

LEMMA 4.4. *Let  $P$  be a matrix polynomial of degree  $k$ . Then*

$$\text{rev}(\mathcal{C}_{-1}(P))^\star(\mu) = (\mu + 1)^k P^\star \left( -\frac{\mu - 1}{\mu + 1} \right), \quad \mu \neq -1, \quad (4.4a)$$

$$\text{rev}(\mathcal{C}_{+1}(P))^\star(\mu) = (-1)^k (1 - \mu)^k P^\star \left( -\frac{1 + \mu}{1 - \mu} \right), \quad \mu \neq 1. \quad (4.4b)$$

*Proof.* We prove (4.4b); the proof of (4.4a) is similar. Since  $\mathcal{C}_{+1}(P)$  and hence  $\mathcal{C}_{+1}(P)^\star$  are matrix polynomials of degree  $k$ ,

$$\begin{aligned} \text{rev}(\mathcal{C}_{+1}(P))^\star(\mu) &= \mu^k (\mathcal{C}_{+1}(P))^\star \left( \frac{1}{\mu} \right) && \text{by (2.1)} \\ &= \mu^k \mathcal{C}_{+1}(P^\star) \left( \frac{1}{\mu} \right) && \text{by (4.3)} \\ &= \mu^k (1 - 1/\mu)^k P^\star \left( \frac{1 + 1/\mu}{1 - 1/\mu} \right) && \text{by (4.2)} \\ &= (-1)^k (1 - \mu)^k P^\star \left( -\frac{1 + \mu}{1 - \mu} \right). \quad \square \end{aligned}$$

THEOREM 4.5. *Let  $P(\lambda)$  be a matrix polynomial of degree  $k$ . Then the correspondence between structure in  $P(\lambda)$  and in its Cayley transformation is as stated in Tables 4.1 and 4.2.*

TABLE 4.1  
Cayley transformations of (anti-)palindromic polynomials

$P(\lambda)$	$\mathcal{C}_{-1}(P)(\mu)$		$\mathcal{C}_{+1}(P)(\mu)$
	$k$ even	$k$ odd	
palindromic	even	odd	even
$\star$ -palindromic	$\star$ -even	$\star$ -odd	$\star$ -even
anti-palindromic	odd	even	odd
$\star$ -anti-palindromic	$\star$ -odd	$\star$ -even	$\star$ -odd

*Proof.* Since the proofs of the equivalences are similar, we only establish one of them. We show that  $P(\lambda)$  is  $\star$ -even if and only if  $\mathcal{C}_{+1}(P)(\mu)$  is  $\star$ -palindromic when  $k$  is even and  $\star$ -anti-palindromic

TABLE 4.2  
Cayley transformations of even/odd polynomials

$P(\lambda)$	$\mathcal{C}_{-1}(P)(\mu)$	$\mathcal{C}_{+1}(P)(\mu)$	
		$k$ even	$k$ odd
even ★-even	palindromic ★-palindromic	palindromic ★-palindromic	anti-palindromic ★-anti-palindromic
odd ★-odd	anti-palindromic ★-anti-palindromic	anti-palindromic ★-anti-palindromic	palindromic ★-palindromic

when  $k$  is odd. Now  $P(\lambda)$  being ★-even is equivalent, by definition, to  $P^\star(-\lambda) = P(\lambda)$  for all  $\lambda$ . Setting  $\lambda = \frac{1+\mu}{1-\mu}$  and multiplying by  $(1-\mu)^k$  yields

$$\begin{aligned}
 P(\lambda) \text{ is } \star\text{-even} &\iff (1-\mu)^k P^\star\left(-\frac{1+\mu}{1-\mu}\right) = (1-\mu)^k P\left(\frac{1+\mu}{1-\mu}\right) \quad \text{for all } \mu \neq 1 \\
 &\iff (-1)^k \text{rev}(\mathcal{C}_{+1}(P))^\star(\mu) = \mathcal{C}_{+1}(P)(\mu) \quad \text{by Lemma 4.4,}
 \end{aligned}$$

from which the desired result follows.  $\square$

Observe that the results in Tables 4.1 and 4.2 are consistent with  $\mathcal{C}_{-1}(P)$  and  $\mathcal{C}_{+1}(P)$  being essentially inverses of each other (see Proposition 4.2).

In this section we have established a relationship between palindromic and odd/even matrix polynomials via the Cayley transformation. Since ★-odd/even matrix polynomials can be interpreted as generalizations of Hamiltonian matrices [28], [29] and since it is well known that Hamiltonian matrices and symplectic matrices are related via the Cayley transformation [26], ★-(anti)-palindromic matrix polynomials can be thought of as generalizations of symplectic matrices.

**5. Vector spaces of linearizations.** A general, systematic approach for constructing linearizations of matrix polynomials has recently been presented in [23]. In this section, we summarize the main results obtained there and then show in the following section how to apply these results to obtain structured linearizations for the various structured matrix polynomials introduced in Section 2.

Let  $P(\lambda) = \sum_{i=0}^k \lambda^i A_i$  be an  $n \times n$  matrix polynomial of degree  $k$  as in (1.1). For *regular matrix polynomials*, it is well known that linearization preserves algebraic and partial multiplicities of all finite eigenvalues [9]. In order to preserve the multiplicities of the eigenvalue  $\infty$ , one has to consider linearizations  $L(\lambda)$  which have the additional property that  $\text{rev}L(\lambda)$  is also a linearization for  $\text{rev}P(\lambda)$ , see [8]. Such linearizations have been named *strong linearizations* in [19]. Both the first and second companion forms are strong linearizations for regular matrix polynomials [8, Proposition 1.1].

The strategy in [23] is to search for strong linearizations for  $P(\lambda)$  among  $kn \times kn$  matrix pencils  $L(\lambda) = \lambda X + Y$  that satisfy

$$L(\lambda) \cdot (A \otimes I_n) := L(\lambda) \begin{bmatrix} \lambda^{k-1} I_n \\ \vdots \\ \lambda I_n \\ I_n \end{bmatrix} = \begin{bmatrix} v_1 P(\lambda) \\ \vdots \\ v_{k-1} P(\lambda) \\ v_k P(\lambda) \end{bmatrix} = v \otimes P(\lambda) \tag{5.1}$$

for some vector  $v \in \mathbb{F}^k$ . Here  $A = [\lambda^{k-1} \ \lambda^{k-2} \ \dots \ \lambda \ 1]^T$ . The pencils in (5.1) generalize the

first companion form and collectively form a vector space denoted by

$$\mathbb{L}_1(P) := \left\{ L(\lambda) = \lambda X + Y : L(\lambda) \cdot (A \otimes I_n) = v \otimes P(\lambda), v \in \mathbb{F}^k \right\}.$$

The vector  $v$  in (5.1) corresponding to  $L(\lambda) \in \mathbb{L}_1(P)$  is called the *right ansatz vector* of  $L(\lambda)$ , because  $L(\lambda)$  is multiplied on the right by  $A \otimes I_n$  to give  $v \otimes P(\lambda)$ . Observe that the first companion form  $C_1(\lambda) \in \mathbb{L}_1(P)$  for any  $P(\lambda)$ , since  $C_1(\lambda) \cdot (A \otimes I_n) = e_1 \otimes P(\lambda)$  always holds.

EXAMPLE 5.1. Consider the matrix polynomial  $P(\lambda) = \lambda^2 A_2 + \lambda A_1 + A_0$ , where  $A_i \in \mathbb{F}^{n \times n}$  and the pencils

$$L_1(\lambda) = \lambda X_1 + Y_1 = \lambda \begin{bmatrix} A_2 & 0 \\ 0 & I_n \end{bmatrix} + \begin{bmatrix} A_1 & A_0 \\ -I_n & 0 \end{bmatrix},$$

and

$$L_2(\lambda) = \lambda X_2 + Y_2 = \lambda \begin{bmatrix} 2A_2 & A_2 \\ A_2 & A_1 \end{bmatrix} + \begin{bmatrix} 2A_1 - A_2 & 2A_0 \\ 0 & A_0 \end{bmatrix}.$$

A straight-forward computation shows that  $L_1(\lambda) \cdot (A \otimes I_n) = e_1 \otimes P(\lambda)$  and  $L_2(\lambda) \cdot (A \otimes I_n) = [2, 1]^T \otimes P(\lambda)$ . Hence,  $L_1(\lambda), L_2(\lambda) \in \mathbb{L}_1(P)$ . Note that  $L_1(\lambda)$  is the first companion form for  $P(\lambda)$ .

The pencil space  $\mathbb{L}_1(P)$  has been designed with the aim of providing an arena of potential linearizations that is fertile enough to contain linearizations that reflect additional structure in  $P$ , but small enough that pencils  $L(\lambda) \in \mathbb{L}_1(P)$  still share the following three properties with the first companion form:

- $L(\lambda)$  is easily constructible from the data in  $P(\lambda)$  (see [23, Thm. 3.5]);
- when  $P(\lambda)$  is regular,  $L(\lambda)$  is a strong linearization for  $P(\lambda)$  if and only if  $L(\lambda)$  is regular [23, Thm. 4.3];
- right eigenvectors of  $P(\lambda)$  are easily recoverable from right eigenvectors of  $L(\lambda)$  (see [23, Thm. 3.8, Thm. 4.4]).

The following tool will be frequently used to construct pencils in  $\mathbb{L}_1(P)$ .

DEFINITION 5.2 (Column shifted sum).

Let  $X = (X_{ij})$  and  $Y = (Y_{ij})$  be matrices in  $\mathbb{F}^{kn \times kn}$  with blocks  $X_{ij}, Y_{ij} \in \mathbb{F}^{n \times n}$ . Then the column shifted sum of  $X$  and  $Y$  is defined to be

$$X \boxplus Y := \begin{bmatrix} X_{11} & \cdots & X_{1k} & 0 \\ \vdots & \ddots & \vdots & \vdots \\ X_{k1} & \cdots & X_{kk} & 0 \end{bmatrix} + \begin{bmatrix} 0 & Y_{11} & \cdots & Y_{1k} \\ \vdots & \vdots & \ddots & \vdots \\ 0 & Y_{k1} & \cdots & Y_{kk} \end{bmatrix},$$

where the zero blocks are also  $n \times n$ .

The column shifted sum  $X \boxplus Y$  is designed to imitate the product of a pencil  $L(\lambda) = \lambda X + Y$  with the block column matrix  $A \otimes I_n$  in the sense of the following lemma.

LEMMA 5.3. For a matrix polynomial  $P(\lambda) = \sum_{i=0}^k \lambda^i A_i$ , a pencil  $L(\lambda) = \lambda X + Y$ , and a vector  $v \in \mathbb{F}^k$  we have

$$(\lambda X + Y) \cdot (A \otimes I_n) = v \otimes P(\lambda) \iff X \boxplus Y = v \otimes [A_k \ A_{k-1} \ \cdots \ A_0]. \quad (5.2)$$

EXAMPLE 5.4. Consider the matrix polynomial  $P(\lambda) = \lambda^2 A_2 + \lambda A_1 + A_0$ , and the pencils  $L_1(\lambda), L_2(\lambda) \in \mathbb{L}_1(P)$  from Example 5.1. Then

$$X_1 \boxplus Y_1 = \begin{bmatrix} A_2 & 0 & 0 \\ 0 & I_n & 0 \end{bmatrix} + \begin{bmatrix} 0 & A_1 & A_0 \\ 0 & -I_n & 0 \end{bmatrix} = \begin{bmatrix} A_2 & A_1 & A_0 \\ 0 & 0 & 0 \end{bmatrix},$$

$$\text{and } X_2 \boxplus Y_2 = \begin{bmatrix} 2A_2 & A_2 & 0 \\ A_2 & A_1 & 0 \end{bmatrix} + \begin{bmatrix} 0 & 2A_1 - A_2 & 2A_0 \\ 0 & 0 & A_0 \end{bmatrix} = \begin{bmatrix} 2A_2 & 2A_1 & 2A_0 \\ A_2 & A_1 & A_0 \end{bmatrix}.$$

The development and analysis of the pencil space  $\mathbb{L}_1(P)$  has a parallel version which generalizes the second companion form  $C_2(\lambda)$ ,

$$\mathbb{L}_2(P) := \left\{ L(\lambda) = \lambda X + Y : (A^T \otimes I_n) \cdot L(\lambda) = w^T \otimes P(\lambda), w \in \mathbb{F}^k \right\}.$$

Here, the vector  $w$  such that  $(A^T \otimes I_n) \cdot L(\lambda) = w^T \otimes P(\lambda)$  is called the *left ansatz vector* for  $L(\lambda) \in \mathbb{L}_2(P)$ . One immediately checks that  $C_2(\lambda) \in \mathbb{L}_2(P)$  with left ansatz vector  $e_1$ . Instead of right eigenvectors, now left eigenvectors of  $P$  are easily recovered from left eigenvectors of linearizations in  $\mathbb{L}_2(P)$  (see [23, Thm. 3.14, Thm. 4.4]).

It is natural to consider pencils in

$$\mathbb{DL}(P) := \mathbb{L}_1(P) \cap \mathbb{L}_2(P),$$

as both right and left eigenvectors of  $P$  are now easily recovered. In fact, it is shown that the left and right ansatz vectors  $v$  and  $w$  must coincide for pencils  $L(\lambda) \in \mathbb{DL}(P)$ .

**THEOREM 5.5** ([23]). *Let  $P(\lambda) = \sum_{i=0}^k \lambda^i A_i$  be a (not necessarily regular) matrix polynomial with coefficients in  $\mathbb{F}^{n \times n}$  and  $A_k \neq 0$ . Then for vectors  $v, w \in \mathbb{F}^k$ , there exists a  $kn \times kn$  matrix pencil  $L(\lambda) = \lambda X + Y$  that simultaneously satisfies*

$$L(\lambda) \cdot (A \otimes I) = v \otimes P(\lambda) \quad \text{and} \quad (A^T \otimes I) \cdot L(\lambda) = w^T \otimes P(\lambda) \quad (5.3)$$

if and only if  $v = w$ . The pencil  $L(\lambda)$  satisfying (5.3) for given  $v = w$  is uniquely determined by  $v$ .

**DEFINITION 5.6.** *For a given  $L(\lambda) \in \mathbb{DL}(P)$ , the vector  $v = w$  from Theorem 5.5 satisfying (5.3) is called the ansatz vector of  $L(\lambda)$ .*

An important advantage of the pencil space  $\mathbb{DL}(P)$  is that there is a simple criterion to characterize the pencils  $L(\lambda) \in \mathbb{DL}(P)$  that are strong linearizations for  $P(\lambda)$ . Let  $v = [v_1, v_2, \dots, v_k]^T$  be the ansatz vector of  $L(\lambda)$ , and define the associated  $v$ -polynomial to be the scalar polynomial  $\mathfrak{p}(x; v) := v_1 x^{k-1} + v_2 x^{k-2} + \dots + v_{k-1} x + v_k$ . By convention, we say that  $\infty$  is a root of  $\mathfrak{p}(x; v)$  if  $v_1 = 0$ . Then the following theorem shows how the roots of the  $v$ -polynomial determine whether  $L(\lambda)$  is a linearization or not.

**THEOREM 5.7** ([23]). *Suppose that  $P(\lambda)$  is a regular matrix polynomial and  $L(\lambda)$  is in  $\mathbb{DL}(P)$  with ansatz vector  $v$ . Then  $L(\lambda)$  is a linearization (indeed a strong linearization) for  $P(\lambda)$  if and only if no root of the  $v$ -polynomial  $\mathfrak{p}(x; v)$  is an eigenvalue of  $P(\lambda)$ . (Note that this statement includes  $\infty$  as one of the possible roots of  $\mathfrak{p}(x; v)$  or possible eigenvalues of  $P(\lambda)$ .)*

**EXAMPLE 5.8.** Consider again the matrix polynomial  $P(\lambda) = \lambda^2 A_2 + \lambda A_1 + A_0$  from Example 5.1 and assume that  $A_2 \neq 0$  and  $P(\lambda)$  is regular. Then one easily verifies that

$$L(\lambda) = \lambda \begin{bmatrix} A_2 & 2A_2 \\ 2A_2 & 2A_1 - A_0 \end{bmatrix} + \begin{bmatrix} A_1 - 2A_2 & A_0 \\ A_0 & 2A_0 \end{bmatrix} \quad (5.4)$$

is in  $\mathbb{DL}(P)$  with ansatz vector  $v = [1, 2]^T$ . The associated  $v$ -polynomial is  $\mathfrak{p}(x; v) = x + 2$  with root  $x = -2$ . Thus  $L(\lambda)$  is a strong linearization for  $P(\lambda)$  if and only if  $-2$  is *not* an eigenvalue of  $P(\lambda)$ .

Note that the pencil  $L(\lambda)$  in Example 5.8 is a *symmetric linearization*, i.e., the matrices in (5.4) are symmetric if all the coefficient matrices  $A_2$ ,  $A_1$ , and  $A_0$  are symmetric. This is true in general for pencils from  $\mathbb{DL}(P)$ . Symmetric linearizations are studied in detail in [11].

**6. Structured linearizations.** We now use the results of Section 5 to construct structure preserving linearizations for matrix polynomials that have one of the structures listed in Table 2.1. We will restrict ourselves to the  $\star$ -variants of these structures (recall that  $\star$  stands either for the transpose  $T$  or the conjugate transpose  $*$ ), because palindromic, anti-palindromic, even, and odd matrix polynomials, in general, cannot be linearized in a structure preserving way. Indeed, consider a regular palindromic polynomial  $P(\lambda)$  of degree  $k \geq 2$ . Any palindromic linearization would have the form  $L(\lambda) = \lambda Z + Z$  for some matrix  $Z$ , and thus have the eigenvalue  $-1$  with geometric multiplicity  $kn$ . However, by [9, Theorem 1.7] a pencil can only be a linearization for a regular matrix polynomial  $P(\lambda)$  if the geometric multiplicity of each eigenvalue of the pencil is less than or equal to  $n$ . Therefore palindromic matrix polynomials do not admit palindromic linearizations. Analogous arguments exclude structured linearizations for anti-palindromic, even, and odd polynomials.

We have seen in Section 5 that for a given matrix polynomial  $P(\lambda)$  of degree  $k$  a pencil  $L(\lambda) \in \mathbb{DL}(P)$  is uniquely determined by its ansatz vector  $v$ . Since pencils from  $\mathbb{DL}(P)$  are always symmetric linearizations, it would be too much to expect to find a linearization in  $\mathbb{DL}(P)$  that reflects additional structures of  $P(\lambda)$  as in Table 2.1. Therefore, we will consider the larger space  $\mathbb{L}_1(P)$  instead. Similar results hold for  $\mathbb{L}_2(P)$ . Let us start with an example.

EXAMPLE 6.1. Consider the quadratic  $T$ -palindromic matrix polynomial  $\lambda^2 A_0^T + \lambda A_1 + A_0$ , where  $A_1 = A_1^T$  and  $A_0 \neq 0$ . We try to construct a pencil  $L(\lambda) \in \mathbb{L}_1(P)$  with a nonzero right ansatz vector  $v = [v_1, v_2]^T \in \mathbb{F}^2$  such that  $L(\lambda)$  is  $T$ -palindromic. The latter condition means that  $L(\lambda)$  must have the block structure

$$L(\lambda) = \lambda Z + Z^T =: \lambda \begin{bmatrix} D & E \\ F & G \end{bmatrix} + \begin{bmatrix} D^T & F^T \\ E^T & G^T \end{bmatrix}$$

with blocks  $D, E, F, G \in \mathbb{F}^{n \times n}$ . Using the column shifted sum  $\boxplus$ , we can write this as

$$Z \boxplus Z^T = \begin{bmatrix} D & E + D^T & F^T \\ F & G + E^T & G^T \end{bmatrix} = \begin{bmatrix} v_1 A_0^T & v_1 A_1 & v_1 A_0 \\ v_2 A_0^T & v_2 A_1 & v_2 A_0 \end{bmatrix}.$$

Comparing blocks in the first and last columns, we obtain  $D = v_1 A_0^T$ ,  $F = v_2 A_0^T = (v_1 A_0)^T$ , and  $G = (v_2 A_0)^T$ . This forces  $v_1 = v_2$ , since we have assumed that  $A_0 \neq 0$ . From the middle column we see that  $E = v_1(A_1 - A_0)$  and that all the equations are consistent, thus yielding

$$L(\lambda) = \lambda Z + Z^T = v_1 \left( \lambda \begin{bmatrix} A_0^T & A_1 - A_0 \\ A_0^T & A_0^T \end{bmatrix} + \begin{bmatrix} A_0 & A_0 \\ A_1 - A_0^T & A_0 \end{bmatrix} \right). \quad (6.1)$$

Example 6.1 illustrates two facts that turn out to be true in general. First, we see that the choice of ansatz vectors  $v$  for which the corresponding  $L(\lambda) \in \mathbb{L}_1(P)$  is  $\star$ -palindromic is restricted. On the other hand, once the ansatz vector  $v$  has been chosen, the pencil  $L(\lambda) \in \mathbb{L}_1(P)$  is uniquely determined by forcing it to be  $T$ -palindromic. The restrictions on the vector  $v$  can be concisely described using the reverse identity  $R_k$  and the diagonal matrix of alternating signs  $\Sigma_k$  as in (2.2).

LEMMA 6.2. *Suppose the matrix polynomial  $P(\lambda)$  is  $\star$ -palindromic or  $\star$ -anti-palindromic. Then for pencils  $L(\lambda) \in \mathbb{L}_1(P)$  with right ansatz vector  $v$ , conditions (i) and (ii) in Table 6.1 are equivalent.*

*Proof.* We consider all eight cases simultaneously. Let  $P(\lambda)$  be  $\star$ -palindromic or  $\star$ -anti-palindromic, so that  $\text{rev} P^\star(\lambda) = \chi_P P(\lambda)$  for  $\chi_P = \pm 1$ .

“(i)  $\Rightarrow$  (ii)”: By (i),  $L(\lambda)$  satisfies  $\text{rev} L^\star(\lambda) = \chi_L L(\lambda)$  for  $\chi_L = \pm 1$ . Since  $L(\lambda) \in \mathbb{L}_1(P)$ ,

$$L(\lambda)(A \otimes I) = v \otimes P(\lambda). \quad (6.2)$$

Taking the reversal of both sides of (6.2), and noting that  $RA = \text{rev} A$ , we have

$$\text{rev} L(\lambda)(R \otimes I)(A \otimes I) = \text{rev} L(\lambda)((\text{rev} A) \otimes I) = v \otimes \text{rev} P(\lambda). \quad (6.3)$$

TABLE 6.1

Structure of $P(\lambda)$	(i) $L(\lambda)$ is	(ii) $(R \otimes I)L(\lambda) \in \mathbb{DL}(P)$ and
$T$ -palindromic	$T$ -palindromic	$Rv = v$
	$T$ -anti-palindromic	$Rv = -v$
$T$ -anti-palindromic	$T$ -palindromic	$Rv = -v$
	$T$ -anti-palindromic	$Rv = v$
*-palindromic	*-palindromic	$Rv = \bar{v}$
	*-anti-palindromic	$Rv = -\bar{v}$
*-anti-palindromic	*-palindromic	$Rv = -\bar{v}$
	*-anti-palindromic	$Rv = \bar{v}$

Now applying the adjoint  $\star$  to both sides, we obtain

$$(A^\star \otimes I)(R \otimes I) \operatorname{rev} L^\star(\lambda^\star) = v^\star \otimes \operatorname{rev} P^\star(\lambda^\star), \quad (6.4)$$

or equivalently,

$$(A^T \otimes I)(R \otimes I)L(\lambda) = (\chi_P \chi_L v^\star) \otimes P(\lambda), \quad (6.5)$$

where we have used the fact that (6.4) is an identity to replace  $\lambda^\star$  by  $\lambda$ , and that  $P(\lambda)$  and  $L(\lambda)$  are either  $\star$ -palindromic or  $\star$ -anti-palindromic. Thus  $(R \otimes I)L(\lambda) \in \mathbb{L}_2(P)$  with left ansatz vector  $w = \chi_P \chi_L (v^\star)^T$ . On the other hand, multiplying (6.2) on the left by  $R \otimes I$  yields

$$(R \otimes I)L(\lambda)(A \otimes I) = (Rv) \otimes P(\lambda), \quad (6.6)$$

showing that  $(R \otimes I)L(\lambda)$  is also in  $\mathbb{L}_1(P)$  with right ansatz vector  $Rv$ . Thus from Theorem 5.5 we conclude that  $(R \otimes I)L(\lambda) \in \mathbb{DL}(P)$  with ansatz vector  $Rv = \chi_P \chi_L (v^\star)^T$ . All eight variants of condition (ii) now follow by noting that  $(v^\star)^T = \bar{v}$  and  $(v^T)^T = v$ .

“(ii)  $\Rightarrow$  (i)”: From  $L(\lambda)(A \otimes I) = v \otimes P(\lambda)$ , we immediately obtain

$$(R \otimes I)L(\lambda)(A \otimes I) = (Rv) \otimes P(\lambda). \quad (6.7)$$

Since  $(R \otimes I)L(\lambda) \in \mathbb{DL}(P)$ , we have from Theorem 5.5 that

$$((A^T R) \otimes I)L(\lambda) = (A^T \otimes I)(R \otimes I)L(\lambda) = (Rv)^T \otimes P(\lambda). \quad (6.8)$$

Applying the adjoint  $\star$  to both ends of (6.8) gives

$$L^\star(\lambda^\star)((R(A^T)^\star) \otimes I) = R(v^T)^\star \otimes P^\star(\lambda^\star),$$

or equivalently

$$L^\star(\lambda)((RA) \otimes I) = R(v^T)^\star \otimes P^\star(\lambda). \quad (6.9)$$

Note that all cases of condition (ii) are expressed by  $R(v^T)^\star = \varepsilon \chi_P v$ , where  $\varepsilon = \pm 1$ . Then taking the reversal of both sides in (6.9) and using  $RA = \operatorname{rev} A$ , we obtain

$$\operatorname{rev} L^\star(\lambda)(A \otimes I) = (\varepsilon \chi_P v) \otimes \operatorname{rev} P^\star(\lambda) = (\varepsilon v) \otimes P(\lambda)$$

or, equivalently,

$$\varepsilon(R \otimes I) \operatorname{rev} L^\star(\lambda)(A \otimes I) = (Rv) \otimes P(\lambda). \quad (6.10)$$

Analogously, starting from identity (6.7), we obtain that

$$\begin{aligned} & (R \otimes I)L(\lambda)(A \otimes I) = (Rv) \otimes P(\lambda) \\ \iff & (A^T \otimes I)L^\star(\lambda)(R \otimes I) = (v^\star R) \otimes P^\star(\lambda) = (v^\star \otimes P^\star(\lambda))(R \otimes I) \\ \iff & (A^T \otimes I)L^\star(\lambda) = v^\star \otimes P^\star(\lambda) \\ \iff & (A^T R \otimes I) \operatorname{rev} L^\star(\lambda) = v^\star \otimes \operatorname{rev} P^\star(\lambda) \\ \iff & (A^T R \otimes I) \operatorname{rev} L^\star(\lambda) = (\varepsilon \chi_P v^T R) \otimes \operatorname{rev} P^\star(\lambda) = (\varepsilon v^T R) \otimes P(\lambda) \\ \iff & (A^T \otimes I) \varepsilon(R \otimes I) \operatorname{rev} L^\star(\lambda) = (Rv)^T \otimes P(\lambda). \end{aligned} \quad (6.11)$$

Thus by (6.10) and (6.11) we have that  $\varepsilon(R \otimes I) \operatorname{rev} L^\star(\lambda)$  is in  $\mathbb{DL}(P)$  with ansatz vector  $Rv$ . By (ii) this is also the case for the pencil  $(R \otimes I)L(\lambda)$ . Then the uniqueness property of Theorem 5.5 implies that

$$\varepsilon(R \otimes I) \operatorname{rev} L^\star(\lambda) = (R \otimes I)L(\lambda),$$

or equivalently  $\varepsilon \operatorname{rev} L^\star(\lambda) = L(\lambda)$ . Hence  $L(\lambda)$  is  $\star$ -palindromic or  $\star$ -anti-palindromic, depending on the parameter  $\varepsilon$ . This implies all the variants of condition (i) in Table 6.2.  $\square$

**THEOREM 6.3.** *Suppose the matrix polynomial  $P(\lambda)$  is  $\star$ -palindromic or  $\star$ -anti-palindromic, so that  $\operatorname{rev} P^\star(\lambda) = \chi_P P(\lambda)$  for  $\chi_P = \pm 1$ , and we are seeking a  $\star$ -palindromic or  $\star$ -anti-palindromic pencil  $L(\lambda)$  in  $\mathbb{L}_1(P)$ , so that  $\operatorname{rev} L^\star(\lambda) = \chi_L L(\lambda)$  for  $\chi_L = \pm 1$ . Then there exists such a structured  $L(\lambda)$  in  $\mathbb{L}_1(P)$  with right ansatz vector  $v$  if and only if the vector  $v$  satisfies  $Rv = \chi_P \chi_L (v^\star)^T$ . Moreover, whenever such a structured  $L(\lambda)$  exists, it is uniquely determined by  $v$ .*

*If  $P(\lambda)$  is regular, then this unique  $L(\lambda)$  is a linearization (and even a strong linearization) for  $P(\lambda)$  if and only if no root of the  $v$ -polynomial  $\mathfrak{p}(x; Rv)$  is an eigenvalue of  $P(\lambda)$ . (Here it is to be understood that  $\infty$  is included as a possible root of  $\mathfrak{p}(x; Rv)$  or eigenvalue of  $P(\lambda)$ .)*

*Proof.* The “ $\Rightarrow$ ” direction of the existence statement is just the (i)  $\Rightarrow$  (ii) part of Lemma 6.2, so we turn immediately to the argument for “ $\Leftarrow$ ”. Suppose  $v \in \mathbb{F}^k$  satisfies the condition  $Rv = \chi_P \chi_L (v^\star)^T$ . Then by Theorem 5.5, let  $\tilde{L}(\lambda)$  be the unique pencil in  $\mathbb{DL}(P)$  with ansatz vector  $Rv$ , and define

$$L(\lambda) := (R \otimes I) \tilde{L}(\lambda). \quad (6.12)$$

Then it is straightforward to show that  $L(\lambda) \in \mathbb{L}_1(P)$  with right ansatz vector  $v$ , and satisfies condition (ii) of Lemma 6.2, hence is the desired structured pencil. The uniqueness of  $L(\lambda)$  follows from Lemma 6.2, together with the uniqueness of  $\tilde{L}(\lambda) = (R \otimes I) L(\lambda)$  as a pencil in  $\mathbb{DL}(P)$  with given ansatz vector  $Rv$ .

Because of (6.12), it is easy to see that  $L(\lambda)$  is a strong linearization for  $P(\lambda)$  if and only if  $\tilde{L}(\lambda)$  is. Thus the last part of the theorem follows immediately from Theorem 5.7.  $\square$

We next present the analogs of Lemma 6.2 and Theorem 6.3 for  $\star$ -even and  $\star$ -odd polynomials.

**LEMMA 6.4.** *Suppose the matrix polynomial  $P(\lambda)$  is  $\star$ -even or  $\star$ -odd. Then for pencils  $L(\lambda) \in \mathbb{L}_1(P)$  with right ansatz vector  $v$ , conditions (i) and (ii) in Table 6.2 are equivalent.*

*Proof.* The proof proceeds in a completely analogous fashion to the proof of Lemma 6.2. The only difference is that in steps of the proof where we took the reversal of two sides of an equation in Lemma 6.2, instead we now simply replace  $\lambda$  by  $-\lambda$ . Observe that replacing  $\lambda$  by  $-\lambda$  in  $A$  has the same effect as premultiplying it by  $\Sigma$ , that is  $\Sigma A = [(-\lambda)^{k-1}, \dots, -\lambda, 1]^T$ .  $\square$

TABLE 6.2

Structure of $P(\lambda)$	(i) $L(\lambda)$ is	(ii) $(\Sigma \otimes I)L(\lambda) \in \mathbb{DL}(P)$ and
$T$ -even	$T$ -even	$\Sigma v = v$
	$T$ -odd	$\Sigma v = -v$
$T$ -odd	$T$ -even	$\Sigma v = -v$
	$T$ -odd	$\Sigma v = v$
*-even	*-even	$\Sigma v = \bar{v}$
	*-odd	$\Sigma v = -\bar{v}$
*-odd	*-even	$\Sigma v = -\bar{v}$
	*-odd	$\Sigma v = \bar{v}$

**THEOREM 6.5.** *Suppose the matrix polynomial  $P(\lambda)$  is  $\star$ -even or  $\star$ -odd, so that  $P^\star(-\lambda) = \varepsilon_P P(\lambda)$  for  $\varepsilon_P = \pm 1$ , and we are seeking a  $\star$ -even or  $\star$ -odd pencil  $L(\lambda)$  in  $\mathbb{L}_1(P)$ , so that  $L^\star(-\lambda) = \varepsilon_L L(\lambda)$  for  $\varepsilon_L = \pm 1$ . Then there exists such a structured  $L(\lambda)$  in  $\mathbb{L}_1(P)$  with right ansatz vector  $v$  if and only if the vector  $v$  satisfies  $\Sigma v = \varepsilon_P \varepsilon_L (v^\star)^T$ . Moreover, whenever such a structured  $L(\lambda)$  exists, it is uniquely determined by  $v$ .*

*If  $P(\lambda)$  is regular, then this unique  $L(\lambda)$  is a linearization (and even a strong linearization) for  $P(\lambda)$  if and only if no root of the  $v$ -polynomial  $\mathfrak{p}(x; \Sigma v)$  is an eigenvalue of  $P(\lambda)$ . (Here it is to be understood that  $\infty$  is included as a possible root of  $\mathfrak{p}(x; \Sigma v)$  or eigenvalue of  $P(\lambda)$ .)*

*Proof.* The proof is completely analogous to that of Theorem 6.3. The only changes are that  $\tilde{L}(\lambda)$  is now the unique pencil in  $\mathbb{DL}(P)$  with ansatz vector  $\Sigma v$ , and  $L(\lambda)$  is defined to be  $(\Sigma \otimes I) \tilde{L}(\lambda)$ .  $\square$

We close this section with some observations on the parallels between the structure of the special ansatz vectors that are admissible for structured linearizations, the structure of the corresponding  $v$ -polynomials and their roots, and the structure of the original matrix polynomial and its eigenvalues. Notice, for example, that ansatz vectors  $v$  satisfying  $Rv = v$  are themselves *palindromic* in the sense that the list of components of  $v$  is identical when read forwards or backwards. Moreover, the corresponding  $v$ -polynomial  $\mathfrak{p}(x; Rv)$  is  $T$ -palindromic (and also palindromic, because it is a scalar polynomial), so by Theorem 2.2 its roots occur in pairs  $(r, 1/r)$ . Analogous observations are compiled in Table 6.3.

**7. When pairs degenerate.** In the last section, we have seen that the search for structured linearizations in  $\mathbb{L}_1(P)$  for structured matrix polynomials leads to the necessity of dealing with ansatz vectors (and corresponding  $v$ -polynomials) that reflect the structure of the matrix polynomial. In particular, the roots of a particular  $v$ -polynomial have to be distinct from the eigenvalues of the matrix polynomial under consideration in order to ensure that the chosen structured pencil from  $\mathbb{L}_1(P)$  is indeed a linearization for the matrix polynomial. This fact becomes delicate when the matrix polynomial  $P(\lambda)$  has even degree, i.e., an ansatz vector  $v$  for a pencil in  $\mathbb{L}_1(P)$  has even dimension, because in this case, the corresponding  $v$ -polynomial  $\mathfrak{p}(x; v)$  has an odd number of roots (counted with multiplicities and including  $\infty$  with multiplicity  $m$  if the first  $m$  components of  $v$  are zero). Since the roots of the  $v$ -polynomial occur in pairs, at least one root must then be from a set of numbers where this pairing degenerates. In the case of conjugate (anti)-palindromic and conjugate even/odd ansatz vectors, these are the unit circle and the real line (including  $\infty$ ), respectively. Thus

TABLE 6.3  
Special ansatz vectors and structures of corresponding  $\mathfrak{v}$ -polynomials

Condition on ansatz vector	Structure of ansatz vector	Structure of $\mathfrak{p}(x; v)$	Pairing of roots of $\mathfrak{p}(x; v)$
$Rv = v$	palindromic	$(T-)$ palindromic	$(r, 1/r)$
$Rv = -v$	anti-palindromic	$(T-)$ anti-palindromic	$(r, 1/r)$
$Rv = \bar{v}$	conjugate palindromic	*-palindromic	$(r, 1/\bar{r})$
$Rv = -\bar{v}$	conjugate anti-palindromic	*-anti-palindromic	$(r, 1/\bar{r})$
$\Sigma v = v$	even	$(T-)$ even	$(r, -r)$
$\Sigma v = -v$	odd	$(T-)$ odd	$(r, -r)$
$\Sigma v = \bar{v}$	conjugate even	*-even	$(r, -\bar{r})$
$\Sigma v = -\bar{v}$	conjugate odd	*-odd	$(r, -\bar{r})$

there exists a continuum of numbers from which this distinguished root of the  $\mathfrak{v}$ -polynomial can be chosen. In particular, this always allows the possibility of choosing an ansatz vector such that the roots of the corresponding  $\mathfrak{v}$ -polynomial are disjoint from the finite set of eigenvalues of  $P(\lambda)$ . In the case of (anti-)palindromic or even/odd ansatz vectors, however, the pairing degenerates for the discrete sets  $\{-1, +1\}$  and  $\{0, \infty\}$ , respectively. Consequently, it is not always possible to choose the roots of the  $\mathfrak{v}$ -polynomial to be disjoint from the eigenvalues of  $P(\lambda)$ . We illustrate this problem in the following with the help of some examples for the case of palindromic structures.

EXAMPLE 7.1. Consider the  $T$ -palindromic matrix polynomial  $\lambda^2 A_0^T + \lambda A_1 + A_0$  from Example 6.1. Since all palindromic ansatz vectors  $v \in \mathbb{F}^2$  are of the form  $v = (v_1, v_1)^T$ , we obtain that any  $T$ -palindromic linearization  $L(\lambda) \in \mathbb{L}_1(P)$  must have the form  $L(\lambda) = \lambda Z + Z^T$  as in (6.1). By Theorem 6.3, we then have  $(R \otimes I)L(\lambda) \in \mathbb{DL}(P)$  with associated vector  $Rv = v$ . The associated  $\mathfrak{v}$ -polynomial is  $\mathfrak{p}(x; Rv) = v_1 x + v_1$  having only the root  $-1$ . Thus, assuming regularity of  $P(\lambda)$ , the pencil

$$\lambda Z + Z^T = v_1 \left( \lambda \begin{bmatrix} A_0^T & A_1 - A_0 \\ A_0^T & A_0^T \end{bmatrix} + \begin{bmatrix} A_0 & A_0 \\ A_1 - A_0^T & A_0 \end{bmatrix} \right).$$

is a (strong) linearization for  $P(\lambda)$  if and only if  $-1$  is not an eigenvalue of  $P(\lambda)$ . On the other hand, in order to construct a  $T$ -anti-palindromic linearization  $\tilde{L}(\lambda) \in \mathbb{L}_1(P)$ , we have to choose an anti-palindromic ansatz vector. All such vectors have the form  $\tilde{v} = (v_1, -v_1)^T \in \mathbb{F}^2$ . The associated  $T$ -anti-palindromic pencil in  $\mathbb{L}_1(P)$  is

$$\tilde{L}(\lambda) := v_1 \left( \lambda \begin{bmatrix} A_0^T & A_1 + A_0 \\ -A_0^T & A_0^T \end{bmatrix} + \begin{bmatrix} -A_0 & A_0 \\ -A_1 - A_0^T & -A_0 \end{bmatrix} \right).$$

Since the associated  $\mathfrak{v}$ -polynomial is  $\mathfrak{p}(x; R\tilde{v}) = -v_1 x + v_1$ , we obtain that  $\tilde{L}(\lambda)$  is a linearization for  $P(\lambda)$  if and only if  $\lambda = 1$  is not an eigenvalue of  $P(\lambda)$ .

From the viewpoint of numerical analysis, one of the main features of using structure preserving methods is the preservation of symmetries in the spectrum. Thus, it makes sense to study both  $T$ -palindromic and  $T$ -anti-palindromic linearizations for a  $T$ -palindromic matrix polynomial  $P(\lambda)$ , because in view of Theorem 2.2, the eigenvalues of  $T$ -anti-palindromic pencils still occur in pairs  $(\lambda, 1/\lambda)$ . However, Example 7.1 shows that a quadratic  $T$ -palindromic matrix polynomial  $P(\lambda)$

having both  $1, -1$  as eigenvalues cannot have a  $T$ -palindromic or  $T$ -anti-palindromic linearization from  $\mathbb{L}_1(P)$ . The question arises if in this case  $P(\lambda)$  has a  $T$ -palindromic linearization that is not from  $\mathbb{L}_1(P)$  or if it has no  $T$ -palindromic linearization at all. The following examples show that both alternatives may occur.

EXAMPLE 7.2. Consider the scalar  $T$ -palindromic matrix polynomial  $P(\lambda) = \lambda^2 - 2\lambda + 1$ . Then the only eigenvalue of  $P(\lambda)$  is  $-1$  and by the observation in Example 7.1 we find that  $P(\lambda)$  cannot have a  $T$ -palindromic linearization from  $\mathbb{L}_1(P)$ . Assume that  $P(\lambda)$  has a  $T$ -palindromic linearization  $L(\lambda)$  that is not from  $\mathbb{L}_1(P)$ . Then  $L(\lambda)$  has the form

$$L(\lambda) = \lambda Z + Z^T = \lambda \begin{bmatrix} w & x \\ y & z \end{bmatrix} + \begin{bmatrix} w & y \\ x & z \end{bmatrix}. \quad (7.1)$$

Since  $\lambda$  is the only eigenvalue of  $P(\lambda)$  with geometric multiplicity one, the same must be true for  $L(\lambda)$ , that is,  $\text{rank } L(-1) = 1$ . But inserting  $\lambda = -1$  in (7.1), we obtain

$$L(-1) = \begin{bmatrix} 0 & y - x \\ x - y & 0 \end{bmatrix}$$

which does not have rank one for any values of  $x, y$ . Thus,  $P(\lambda)$  does not have any  $T$ -palindromic linearization.

EXAMPLE 7.3. Consider the  $T$ -palindromic matrix polynomial

$$P(\lambda) = \lambda^2 \begin{bmatrix} 0 & 1 \\ -1 & 0 \end{bmatrix} + \begin{bmatrix} 0 & -1 \\ 1 & 0 \end{bmatrix}.$$

Then  $P(\lambda)$  has the eigenvalues  $1$  and  $-1$  both with algebraic multiplicity two and thus,  $P(\lambda)$  does not have a  $T$ -palindromic linearization from  $\mathbb{L}_1(P)$ . Starting with the first companion form  $C_1(\lambda)$ , we obtain that

$$\begin{bmatrix} 1 & 0 & 0 & 0 \\ 0 & 0 & 0 & 1 \\ 0 & 0 & 1 & 0 \\ 0 & 1 & 0 & 0 \end{bmatrix} \cdot C_1(\lambda) \cdot \begin{bmatrix} 1 & 0 & 0 & 0 \\ 0 & 0 & -1 & 0 \\ 0 & 1 & 0 & 0 \\ 0 & 0 & 0 & 1 \end{bmatrix} = \lambda \begin{bmatrix} 0 & 0 & -1 & 0 \\ 0 & 0 & 0 & 1 \\ 0 & 1 & 0 & 0 \\ -1 & 0 & 0 & 0 \end{bmatrix} + \begin{bmatrix} 0 & 0 & 0 & -1 \\ 0 & 0 & 1 & 0 \\ -1 & 0 & 0 & 0 \\ 0 & 1 & 0 & 0 \end{bmatrix}$$

is a  $T$ -palindromic linearization for  $P(\lambda)$ . Observe that this linearization is neither in  $\mathbb{L}_1(P)$  nor in  $\mathbb{L}_2(P)$ .

EXAMPLE 7.4. Consider the scalar  $T$ -anti-palindromic matrix polynomial  $P(\lambda) = \lambda^2 - 1$  with roots  $\pm 1$ . Assume that  $L_\varepsilon(\lambda) = \lambda Z + \varepsilon Z^T$  is a linearization for  $P(\lambda)$ , where  $\varepsilon = \pm 1$ . Then  $L_\varepsilon(\lambda)$  is  $T$ -palindromic if  $\varepsilon = 1$  and  $T$ -anti-palindromic if  $\varepsilon = -1$ . Since  $P(\lambda)$  does not have the eigenvalue  $\infty$ , we obtain that  $Z$  is invertible and  $L_\varepsilon(\lambda)$  is equivalent to the pencil  $\lambda I + \varepsilon Z^{-1} Z^T$ . Being a linearization for  $P(\lambda)$ , the matrix  $\varepsilon Z^{-1} Z^T$  must have eigenvalues  $+1$  and  $-1$ , and hence determinant  $-1$ . However, we obtain that

$$\det \varepsilon Z^{-1} Z^T = \varepsilon^2 \frac{1}{\det Z} \det Z = 1$$

which is a contradiction. Thus,  $P(\lambda)$  neither has a  $T$ -palindromic linearization, nor a  $T$ -anti-palindromic linearization.

As the examples show, the eigenvalues  $-1$  and  $1$  may cause trouble in the context of finding structure preserving linearizations for  $T$ -palindromic or  $T$ -anti-palindromic matrix polynomials. A possibility for circumventing this problem is to first deflate the eigenvalues  $1$  and  $-1$  with a direct procedure working on the original matrix polynomial. The resulting matrix polynomial then does

not have the eigenvalues 1 or  $-1$  and thus, a structure preserving linearization from  $\mathbb{L}_1(P)$  can be constructed. Such deflating strategies are currently under investigation.

Recall that the problems concerning the eigenvalues 1 and  $-1$  only occur in the transpose case, but not in the conjugate transpose case. Indeed, consider a regular  $*$ -palindromic matrix polynomial  $P(\lambda)$  of degree  $k$ . Then the  $\mathbf{v}$ -polynomial  $\mathbf{p}(x; Rv)$  corresponding to a vector  $Rv = \bar{v}$  is again  $*$ -palindromic and has  $k-1$  roots (possibly including  $\infty$ ), that occur in pairs  $(\lambda, 1/\bar{\lambda})$  by Theorem 2.2. Thus, if  $k$  is even, then at least one root of  $\mathbf{p}(x; Rv)$  must lie on the unit circle, but  $v$  can always be chosen in such a way that the set of roots of the corresponding  $\mathbf{v}$ -polynomial  $\mathbf{p}(x; Rv)$  and the spectrum of  $P(\lambda)$  are disjoint. The following example illustrates this fact for the case  $k = 2$ .

**EXAMPLE 7.5.** Consider a  $*$ -palindromic matrix polynomial  $P(\lambda) = \lambda^2 A_0^* + \lambda A_1 + A_0$ , where  $A_1 = A_1^*$  and assume that  $P(\lambda)$  is regular. Furthermore, assume that  $\zeta \in \mathbb{C}$  has modulus one and is not an eigenvalue of  $P(\lambda)$ . Let  $\alpha \in \mathbb{C} \setminus \{0\}$  be such that  $\zeta = -\alpha/\bar{\alpha}$ . Then  $v = (\alpha, \bar{\alpha})^T$  satisfies  $Rv = \bar{v}$  and the  $\mathbf{v}$ -polynomial associated with  $Rv$  is  $\mathbf{p}(x; Rv) = \bar{\alpha}x + \alpha$  having the root  $\zeta$ . Then the pencil

$$L(\lambda) = \lambda \begin{bmatrix} \alpha A_0^* & \alpha A_1 - \bar{\alpha} A_0 \\ \bar{\alpha} A_0^* & \alpha A_0^* \end{bmatrix} + \begin{bmatrix} \bar{\alpha} A_0 & \alpha A_0 \\ \bar{\alpha} A_1 - \alpha A_0^* & \bar{\alpha} A_0 \end{bmatrix} \in \mathbb{L}_1(P)$$

is  $*$ -palindromic and is a linearization for  $P(\lambda)$  by Theorem 6.3.

**8. Construction of structured linearizations.** We now discuss an approach for the construction of structured linearizations  $L(\lambda) \in \mathbb{L}_1(P)$  for  $\star$ -even,  $\star$ -odd,  $\star$ -palindromic, or  $\star$ -anti-palindromic matrix polynomials. (Recall that  $\star \in \{T, *\}$ .) Since we know from Theorem 6.5 and Theorem 6.3 that  $\star$ -(anti)-palindromic linearizations in  $\mathbb{L}_1(P)$  satisfy  $(R \otimes I)L(\lambda) \in \mathbb{DL}(P)$  and  $\star$ -even or  $\star$ -odd linearizations in  $\mathbb{L}_1(P)$  satisfy  $(\Sigma \otimes I)L(\lambda) \in \mathbb{DL}(P)$ , we could use the explicit formulas for the blocks of a pencil in  $\mathbb{DL}(P)$  given in [23, Theorem 5.3]. Alternatively, one can also use the following column/block-wise step-by-step procedure, which we first illustrate with the help of an example.

Given a  $T$ -palindromic matrix polynomial  $P(\lambda) = \lambda^3 A^T + \lambda^2 B^T + \lambda B + A$ , we construct a  $T$ -palindromic pencil  $L(\lambda) \in \mathbb{L}_1(P)$ . By Theorem 6.3, the corresponding right ansatz vector  $v$  must satisfy  $Rv = v$ , so let us choose  $v = [1, -1, 1]^T$ . The  $\mathbf{v}$ -polynomial corresponding to  $Rv$  is  $\mathbf{p}(x; Rv) = x^2 - x + 1$ , whose roots  $\frac{1}{2}(1 \pm i\sqrt{3})$  have to be excluded as eigenvalues of  $P(\lambda)$ . Let  $\lambda Z + Z^T := L(\lambda)$ . Using the shifted sum  $\boxplus$ , we obtain

$$Z \boxplus Z^T = \begin{bmatrix} A^T & B^T & B & A \\ -A^T & -B^T & -B & -A \\ A^T & B^T & B & A \end{bmatrix}. \quad (8.1)$$

By the definition of the shifted sum, the first block column of  $Z$  and the last block column of  $Z^T$  are now uniquely determined. Hence

$$\lambda Z + Z^T = \lambda \begin{bmatrix} A^T & * & * \\ -A^T & * & * \\ A^T & * & * \end{bmatrix} + \begin{bmatrix} * & * & A \\ * & * & -A \\ * & * & A \end{bmatrix}, \quad (8.2)$$

where  $*$  represents  $n \times n$  blocks yet to be determined. We now continue by alternately using the fact that  $L(\lambda)$  is  $T$ -palindromic and that  $L(\lambda)$  is in  $\mathbb{L}_1(P)$ . Thus, observing that the second matrix in (8.2) is just the transpose of the first one, we obtain

$$\lambda Z + Z^T = \lambda \begin{bmatrix} A^T & * & * \\ -A^T & * & * \\ A^T & -A^T & A^T \end{bmatrix} + \begin{bmatrix} A & -A & A \\ * & * & -A \\ * & * & A \end{bmatrix}.$$



Again, each panel labelled with an odd number is constructed using information from the fact that the desired pencil is in  $\mathbb{L}_1(P)$ , while each panel labelled with an even number is constructed using information on the structure of the matrices of the pencil. A complete list of structured linearizations for structured matrix polynomials of degree two is given in Table 9.1. We do not list  $\star$ -odd and  $\star$ -anti-palindromic matrix polynomials, because they can be easily transformed into  $\star$ -even and  $\star$ -palindromic matrix polynomials by multiplication with the imaginary unit  $i$ . Some selected structured linearizations for  $\star$ -palindromic and  $\star$ -even matrix polynomials of degree three are given in Table 9.2 and Table 9.3.

**9. Concluding Summary.** For matrix polynomials that are  $\star$ -even/odd or  $\star$ -(anti)-palindromic, we have shown that pencils with the same (or “opposite”) structure can always be found in  $\mathbb{L}_1(P)$ , the vector space of potential linearizations introduced in [23]. We have presented an effective procedure to systematically construct these structured pencils, and developed a simple criterion to determine when these pencils are linearizations. As shown in [13], [14], numerical methods based on these structured linearizations are expected to be more effective in computing accurate eigenvalues in practical applications.

**Acknowledgment** We thank the mathematics departments of the universities of Manchester, and TU Berlin and the Banff International Research Station for giving us the opportunity to carry out this joint research. We thank Fran Tisseur for helpful comments on an earlier draft, and Ralph Byers for several enlightening discussions on the topic.

#### REFERENCES

- [1] E. Anderson, Z. Bai, C. Bischof, J. Demmel, J. Dongarra, J. Du Croz, A. Greenbaum, S. Hammarling, A. McKenney, S. Ostrouchov, and D. Sorensen. *LAPACK Users' Guide*. SIAM, Philadelphia, PA, second edition, 1995.
- [2] T. Apel, V. Mehrmann, and D. Watkins. Structured eigenvalue methods for the computation of corner singularities in 3D anisotropic elastic structures. *Comp. Meth. Appl. Mech. Eng.*, 191:4459–4473, 2002.
- [3] T. Apel, V. Mehrmann, and D. Watkins. Numerical solution of large scale structured polynomial eigenvalue problems. In *Foundations of Computational Mathematics*. Springer Verlag, 2003.
- [4] P. Benner, R. Byers, V. Mehrmann, and H. Xu. Numerical computation of deflating subspaces of skew Hamiltonian/Hamiltonian pencils. *SIAM J. Matrix Anal. Appl.*, 24:165–190, 2002.
- [5] D. Chu, X. Liu, and V. Mehrmann. A numerically backwards stable method for computing the Hamiltonian Schur form. Preprint 2004/24, Institut für Mathematik, TU Berlin, D-10623 Berlin, FRG, 2004. url: <http://www.math.tu-berlin.de/preprints/>.
- [6] H. Faßbender. *Symplectic Methods for the Symplectic Eigenvalue Problem*. Kluwer Academic, New York, 2000.
- [7] F.R. Gantmacher. *Theory of Matrices*, volume 2. Chelsea, New York, 1959.
- [8] I. Gohberg, M.A. Kaashoek, and P. Lancaster. General theory of regular matrix polynomials and band Toeplitz operators. *Integr. Eq. Operator Theory*, 11(6):776–882, 1988.
- [9] I. Gohberg, P. Lancaster, and L. Rodman. *Matrix Polynomials*. Academic Press, New York, 1982.
- [10] I. Gohberg, P. Lancaster, and L. Rodman. *Matrices and Indefinite Scalar Products*. Birkhauser, Basel, 1983.
- [11] N.J. Higham, D.S. Mackey, N. Mackey, and F. Tisseur. Symmetric linearizations for matrix polynomials. Numerical analysis report, Manchester Centre for Computational Mathematics, Manchester, England, 2005. In preparation.
- [12] N.J. Higham, F. Tisseur, and P.M. Van Dooren. Detecting a definite Hermitian pair and a hyperbolic or elliptic quadratic eigenvalue problem, and associated nearness problems. *Linear Algebra Appl.*, 351–352:455–474, 2002.
- [13] A. Hilliges. Numerische Lösung von quadratischen Eigenwertproblemen mit Anwendung in der Schienendynamik. Diplomarbeit, TU Berlin, Inst. f. Mathematik, 2004.
- [14] A. Hilliges, C. Mehl, and V. Mehrmann. On the solution of palindromic eigenvalue problems. In *Proceedings of the 4th European Congress on Computational Methods in Applied Sciences and Engineering (ECCOMAS)*. Jyväskylä, Finland, 2004. CD-ROM.
- [15] Peter Hilton. Personal communication, Oct 2004. See also Miscellanea, College Math. J., Nov 1999.
- [16] Ilse C.F. Ipsen. Accurate eigenvalues for fast trains. *SIAM News*, 37(9):1–2, Nov 2004.
- [17] V.A. Kozlov, V.G. Maz'ya, and J. Roßmann. Spectral properties of operator pencils generated by elliptic boundary value problems for the Lamé system. *Rostocker Math. Kolloq.*, 51:5–24, 1997.

- [18] P. Lancaster. *Lambda-matrices and Vibrating Systems*. Pergamon Press, Oxford, 1966.
- [19] P. Lancaster and P. Psarrakos. A note on weak and strong linearizations of regular matrix polynomials. Unpublished 5-page note, 2004.
- [20] P. Lancaster and L. Rodman. *The Algebraic Riccati Equation*. Oxford University Press, Oxford, 1995.
- [21] D. Leguillon. Computation of 3d-singularities in elasticity. In M. Costabel et al., editor, *Boundary value problems and integral equations in nonsmooth domains*, volume 167 of *Lect. Notes Pure Appl. Math.*, pages 161–170, New York, 1995. Marcel Dekker. Proceedings of the conference, held at the CIRM, Luminy, France, May 3-7, 1993.
- [22] R. B. Lehoucq, D. C. Sorensen, and C. Yang. *ARPACK Users' Guide: Solution of Large-Scale Eigenvalue Problems with Implicitly Restarted Arnoldi Methods*. SIAM, Philadelphia, 1998.
- [23] D. Steven Mackey, Niloufer Mackey, Christian Mehl, and Volker Mehrmann. Vector spaces of linearizations for matrix polynomials. Numerical Analysis Report No. 464, Manchester Centre for Computational Mathematics, Manchester, England, 2005.
- [24] D. Steven Mackey, Niloufer Mackey, and Françoise Tisseur. Structured factorizations in scalar product spaces. Numerical Analysis Report No. 432, Manchester Centre for Computational Mathematics, Manchester, England, 2004. To appear in *SIAM J. Matrix Anal. Appl.* .
- [25] MATLAB, Version 5. The MathWorks, inc., 24 Prime Park Way, Natick, MA 01760-1500, USA, 1996.
- [26] V. Mehrmann. *The Autonomous Linear Quadratic Control Problem, Theory and Numerical Solution*. Number 163 in Lecture Notes in Control and Information Sciences. Springer-Verlag, Heidelberg, July 1991.
- [27] V. Mehrmann. A step toward a unified treatment of continuous and discrete time control problems. *Linear Algebra Appl.*, 241–243:749–779, 1996.
- [28] V. Mehrmann and D. Watkins. Structure-preserving methods for computing eigenpairs of large sparse skew-Hamiltonian/Hamiltonian pencils. *SIAM J. Sci. Comput.*, 22:1905–1925, 2001.
- [29] V. Mehrmann and D. Watkins. Polynomial eigenvalue problems with Hamiltonian structure. *Electr. Trans. Num. Anal.*, 13:106–113, 2002.
- [30] H. Schmitz, K. Volk, and W. L. Wendland. On three-dimensional singularities of elastic fields near vertices. *Numer. Methods Partial Differ. Equations*, 9:323–337, 1993.
- [31] F. Tisseur and K. Meerbergen. A survey of the quadratic eigenvalue problem. *SIAM Rev.*, 43:234–286, 2001.
- [32] H. Xu. Equivalence between generalized symplectic pencil and skew-Hermitian/Hermitian pencil. Technical Report 175, DFG Research Center MATHEON, *Mathematics for key technologies* in Berlin, TU Berlin, Str. des 17. Juni 136, D-10623 Berlin, Germany, 2005. [url: http://www.math.tu-berlin.de/DFG-Forschungszentrum/preprints/](http://www.math.tu-berlin.de/DFG-Forschungszentrum/preprints/).
- [33] S. Zaglmayr. Eigenvalue problems in SAW-filter simulations. Diplomarbeit, Inst. of Comp. Mathematics, J. Kepler Univ. Linz, Austria, 2002.

TABLE 9.1

Structured linearizations for  $\lambda^2 A + \lambda B + C$ . Except for the parameters  $r \in \mathbb{R}$  and  $z \in \mathbb{C}$ , the linearizations are unique up to a (suitable) scalar factor. The last column lists the roots of the  $v$ -polynomial  $\mathfrak{p}(x; Tv)$  corresponding to  $T = R$  or  $T = \Sigma$ , respectively.

structure of $P(\lambda)$	structure of $L(\lambda)$	$v$	$L(\lambda)$ corresponding to $v$	root of $\mathfrak{p}(x; Tv)$
$T$ -palindromic	$T$ -palindromic	$\begin{bmatrix} 1 \\ 1 \end{bmatrix}$	$\lambda \begin{bmatrix} A & B-C \\ A & A \end{bmatrix} + \begin{bmatrix} C & C \\ B-A & C \end{bmatrix}$	$-1$
$A = C^T$ $B = B^T$	anti- $T$ -palindromic.	$\begin{bmatrix} 1 \\ -1 \end{bmatrix}$	$\lambda \begin{bmatrix} A & B+C \\ -A & A \end{bmatrix} + \begin{bmatrix} -C & C \\ -B-A & -C \end{bmatrix}$	$1$
anti- $T$ -palindromic.	$T$ -palindromic	$\begin{bmatrix} 1 \\ -1 \end{bmatrix}$	$\lambda \begin{bmatrix} A & B+C \\ -A & A \end{bmatrix} + \begin{bmatrix} -C & C \\ -B-A & -C \end{bmatrix}$	$1$
$A = -C^T$ $B = -B^T$	anti- $T$ -palindromic	$\begin{bmatrix} 1 \\ 1 \end{bmatrix}$	$\lambda \begin{bmatrix} A & B-C \\ A & A \end{bmatrix} + \begin{bmatrix} C & C \\ B-A & C \end{bmatrix}$	$-1$
*-palindromic	*-palindromic	$\begin{bmatrix} z \\ \bar{z} \end{bmatrix}$	$\lambda \begin{bmatrix} zA & zB - \bar{z}C \\ \bar{z}A & zA \end{bmatrix} + \begin{bmatrix} \bar{z}C & zC \\ \bar{z}B - zA & \bar{z}C \end{bmatrix}$	$-z/\bar{z}$
$A = C^*$ $B = B^*$	anti-*-palindromic	$\begin{bmatrix} z \\ -\bar{z} \end{bmatrix}$	$\lambda \begin{bmatrix} zA & zB + \bar{z}C \\ -\bar{z}A & zA \end{bmatrix} + \begin{bmatrix} -\bar{z}C & zC \\ -\bar{z}B - zA & -\bar{z}C \end{bmatrix}$	$z/\bar{z}$
$T$ -even	$T$ -even	$\begin{bmatrix} 0 \\ 1 \end{bmatrix}$	$\lambda \begin{bmatrix} 0 & -A \\ A & B \end{bmatrix} + \begin{bmatrix} A & 0 \\ 0 & C \end{bmatrix}$	$\infty$
$A = A^T$ $B = -B^T$ $C = C^T$	$T$ -odd	$\begin{bmatrix} 1 \\ 0 \end{bmatrix}$	$\lambda \begin{bmatrix} A & 0 \\ 0 & C \end{bmatrix} + \begin{bmatrix} B & C \\ -C & 0 \end{bmatrix}$	$0$
$T$ -odd	$T$ -even	$\begin{bmatrix} 1 \\ 0 \end{bmatrix}$	$\lambda \begin{bmatrix} A & 0 \\ 0 & C \end{bmatrix} + \begin{bmatrix} B & C \\ -C & 0 \end{bmatrix}$	$0$
$A = -A^T$ $B = B^T$ $C = -C^T$	$T$ -odd	$\begin{bmatrix} 0 \\ 1 \end{bmatrix}$	$\lambda \begin{bmatrix} 0 & -A \\ A & B \end{bmatrix} + \begin{bmatrix} A & 0 \\ 0 & C \end{bmatrix}$	$\infty$
*-even	*-even	$\begin{bmatrix} i \\ r \end{bmatrix}$	$\lambda \begin{bmatrix} iA & -rA \\ rA & rB + iC \end{bmatrix} + \begin{bmatrix} rA + iB & iC \\ -iC & rC \end{bmatrix}$	$ir$
$A = A^*$ $B = -B^*$ $C = C^*$	*-odd	$\begin{bmatrix} r \\ i \end{bmatrix}$	$\lambda \begin{bmatrix} rA & -iA \\ iA & iB + rC \end{bmatrix} + \begin{bmatrix} iA + rB & rC \\ -rC & iC \end{bmatrix}$	$-\frac{i}{r}$

TABLE 9.2

$\star$ -palindromic linearizations for the cubic  $\star$ -palindromic matrix polynomial  $\lambda^3 A^\star + \lambda^2 B^\star + \lambda B + A$ . The last column lists the roots of the  $v$ -polynomial  $\mathfrak{p}(x; Rv)$  corresponding to  $Rv$ . The third linearization can be seen to be a linear combination of the first two linearizations. (Recall that  $\star$  is either  $T$  or  $\ast$ .)

$v$	$L(\lambda)$ corresponding to $v$	roots of $\mathfrak{p}(x; Rv)$
$\begin{bmatrix} 0 \\ 1 \\ 0 \end{bmatrix}$	$\lambda \begin{bmatrix} 0 & 0 & -A \\ A^\star & B^\star & 0 \\ 0 & A^\star & 0 \end{bmatrix} + \begin{bmatrix} 0 & A & 0 \\ 0 & B & A \\ -A^\star & 0 & 0 \end{bmatrix}$	$0, \infty$
$\begin{bmatrix} 1 \\ 0 \\ 1 \end{bmatrix}$	$\lambda \begin{bmatrix} A^\star & B^\star - A & B \\ 0 & A^\star - B & B^\star - A \\ A^\star & 0 & A^\star \end{bmatrix} + \begin{bmatrix} A & 0 & A \\ B - A^\star & A - B^\star & 0 \\ B^\star & B - A^\star & A \end{bmatrix}$	$i, -i$
$\begin{bmatrix} 1 \\ 1 \\ 1 \end{bmatrix}$	$\lambda \begin{bmatrix} A^\star & B^\star - A & B - A \\ A^\star & B^\star + A^\star - B & B^\star - A \\ A^\star & A^\star & A^\star \end{bmatrix} + \begin{bmatrix} A & A & A \\ B - A^\star & B + A - B^\star & A \\ B^\star - A^\star & B - A^\star & A \end{bmatrix}$	$\frac{-1 \pm i\sqrt{3}}{2}$

TABLE 9.3

$\star$ -even linearizations for the  $\star$ -even matrix polynomial  $\lambda^3 A + \lambda^2 B + \lambda C + D$ , where  $A = -A^\star$ ,  $B = B^\star$ ,  $C = -C^\star$ ,  $D = D^\star$ . The last column lists the roots of the  $v$ -polynomial  $\mathfrak{p}(x; \Sigma v)$  corresponding to  $\Sigma v$ . The third linearization can be seen to be a linear combination of the first two linearizations. (Recall that  $\star$  is either  $T$  or  $\ast$ .)

$v$	$L(\lambda)$ corresponding to $v$	roots of $\mathfrak{p}(x; \Sigma v)$
$\begin{bmatrix} 0 \\ 0 \\ 1 \end{bmatrix}$	$\lambda \begin{bmatrix} 0 & 0 & A \\ 0 & -A & -B \\ A & B & C \end{bmatrix} + \begin{bmatrix} 0 & -A & 0 \\ A & B & 0 \\ 0 & 0 & D \end{bmatrix}$	$\infty$
$\begin{bmatrix} 1 \\ 0 \\ 0 \end{bmatrix}$	$\lambda \begin{bmatrix} A & 0 & 0 \\ 0 & C & D \\ 0 & -D & 0 \end{bmatrix} + \begin{bmatrix} B & C & D \\ -C & -D & 0 \\ D & 0 & 0 \end{bmatrix}$	$0$
$\begin{bmatrix} 1 \\ 0 \\ 4 \end{bmatrix}$	$\lambda \begin{bmatrix} A & 0 & 4A \\ 0 & C - 4A & D - 4B \\ 4A & 4B - D & 4C \end{bmatrix} + \begin{bmatrix} B & C - 4A & D \\ 4A - C & 4B - D & 0 \\ D & 0 & 4D \end{bmatrix}$	$2i, -2i$